

YOUNG HEUNG

IRON & STEEL CO., LTD.



WELCOME TO OUR COMPANY

YOUNG HEUNG IRON & STEEL CO.,LTD. is among the premier producers in the field of steel wire products, striving always to beat industry standard.

The motto of our company has been HONESTY, ORIGINALITY and SERVICE since established in 1977.

YOUNG HEUNG IRON & STEEL CO.,LTD. has been continually taking pains to reach the highest quality by high-qualified engineers and accumulated technology for our product ; WIRE ROPE, HARD DRAWN STEEL WIRE, GALVANIZED STEEL WIRE & STRANDS, GALVANIZED AIRCRAFT CABLE, INNER CABLE, STEEL BARS FOR PRESTRESSED CONCRETE, LOW RELAXATION STEEL STRANDS FOR PRESTRESSED CONCRETE & COLD DRAWN STEEL BAR.

We believe YOUNG HEUNG IRON & STEEL CO.,LTD. has reached international prominence within the complex steel industry of wire producing companies.

The continuing challenge for the 21st century is our promise to always improve our products and maintain leadership in our products.

We will contribute both the highest quality and the best service to our customers.

YOU can be assured of our COMPETITIVE PRICING POLICY.

The BEST QUALITY, FAST and TIMELY DELIVERY and EXCELLENT SERVICE.

BRIEF HISTORY

1977.	20.	Apr.	The Company was established
1979.	5.	Jun.	Completed 1st expansion plant
1979.	1.	Sep.	Approval of Korean Industrial Standard (Wire Rope & Hard drawn Steel Wire)
1983.	27.	Dec.	Approval of Korean Industrial Standard (Galv. Steel Wire Strands)
1987.	15.	Oct.	Paid in Capital was increased to 5Billion won
1989.	5.	Jul.	Approval Japanese Industrial Standard(Wire Rope)
1994.	8.	Sep.	Approval of ISO 9001(LRQA)
1996.	16.	Nov.	Approval of Korean Industrial Standard (Steel Bars for Prestressed Concrete & Low Relaxation Steel Strands for Prestressed Concrete)
2001.	13.	Aug.	Approval of Japanese Industrial Standard(PC Strands)
2004.	28.	Apr.	Approval of Japanese Industrial Standard (Galv. Steel Wire Strands & Hard drawn Steel Wire)
2004.	22.	Dec.	Merged in the KISCO Group (KOREA IRON & STEEL CO.,LTD.)
2008.	07.	Mar.	Approval of API 9A Quality System (API)



Highest quality, highest service

CONTENTS

Welcome to our company/Brief History	2
Wire Rope	5
General information	6
Typical rope constructions	10
Federal specification	14
API Specification	18
BS specification	19
JIS specification	23
Unique Rope	28
Swaged Wire Rope	30
Compact Wire Rope	32
YG-5 Wire Rope	36
Plastic Impregnated Wire Rope	39
Elevator Wire Rope	40
Cable Laid Rope	42
Galvanized Steel Wire Strand	43
Hard Drawn Steel Wire	44
Piano Wire	45
Standard Lubrication Chart for Wire	46
How To Order Steel Wire Rope	49
GAC & Inner Cable	52
Low Relaxation Prestressed Concrete	57
X-Bon/ Super-Bon	58
Cold Drawn Steel Bars	59
General Information	60
Free Cutting Steel	61
Machine Structural Carbon Steel	62
Spring Steels & Machine Structural Alloy Steels	63
Reference Charts	64

WIRE ROPE

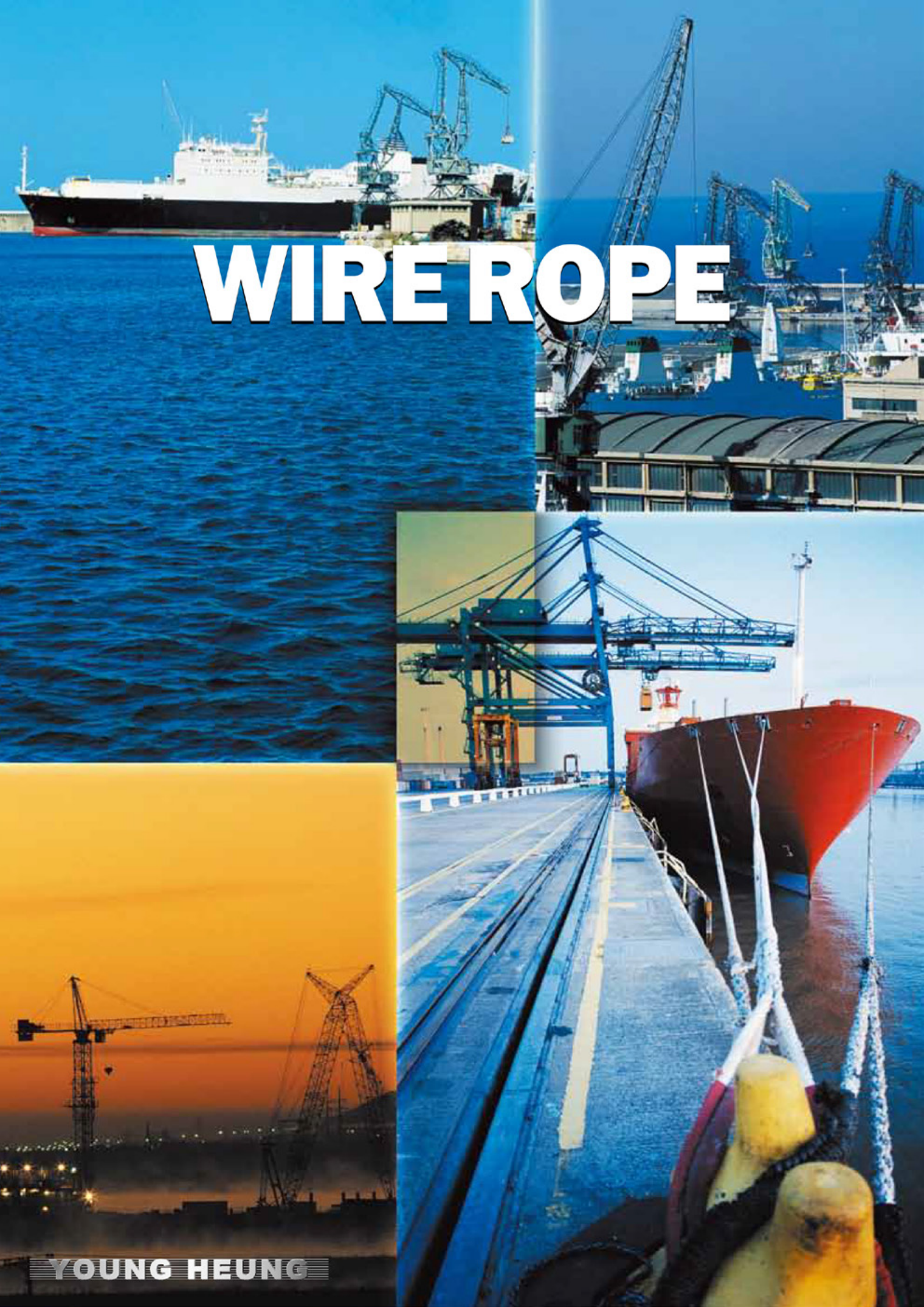



WIRE ROPE

THE TECHNICAL SPECIALITY OF YOUNG HEUNG

A. THE MOST IMPROVED FACILITY FOR PATENTING

Young Heung' s patenting process has an in-line facility, which consistently sets Heat-treatment and Pickling.

This in-line process creates the maximum Heat-treatment proficiency and perfectly manufactured products.

B. OUR NEW MODERNIZED ZINC COATING PROCESS

Young Heung uses a ceramic galvanizing furnace resulting in high quality galvanized finished wire products.

C. "SUPER POWER" ROPE

Young Heung' s new modernized facility can answer all our customers' requests for high quality wire ropes.

D. SPECIAL WIRE DEVELOPMENT

Young Heung' s technical superiority permits us to produce special wire ropes such as high grade mining, compact, swaged and elevator wire ropes in addition to our highly reputed General Purpose Wire Ropes.

E. SPECIALITY OF PRODUCTION PROCESS

Young Heung continues in our effort to improve our production manufacturing process, including pre-forming, post-forming, pretension etc.



1. Construction of wire rope

The design of a rope is determined by

STRAND CONSTRUCTION

The number and arrangement of wires in each strand

ROPE CONSTRUCTION

The number and arrangement of strands in each rope

THE CORE



2. Grades of rope wire

Young Heung wire ropes are made of steel wires classified into following tensile strength grades to meet various requirements according to the applications.

Grade 135 kg/mm^2 : Special grade to meet requirement of hoisting ropes on traction elevators

Grade 150/160 kg/mm^2 : Galvanized wires coated with zinc through hot dip process for protection against corrosion

Grade 165 kg/mm^2 : Ungalvanized and drawn galvanized wires for general purpose wire ropes.

Grade 180 kg/mm^2 : Ungalvanized high tensile grade wires for general purpose wire ropes.

Grade 195 kg/mm^2 : Extra high tensile grade is used in the manufacture of wire rope where ultimate breaking strength is required.



3. Wire rope lay

Right lay : Clockwise

Left lay : Counter-clockwise

Regular lay : Wires in strands are laid in the opposite direction of the strands and are parallel to the rope axis.
Ropes with regular lay are easy to handle and have greater resistance to crushing than those with lang lay.

Lang lay : Wires are laid in the same direction as the strands of the rope, and in an angle to the rope axis.
Longer lengths of the individual wires are exposed, creating greater resistance to wear and improved flexibility.
Lang lay ropes should only be used where both rope ends are “fixed” and therefore, should not be used with a swivel type terminal.

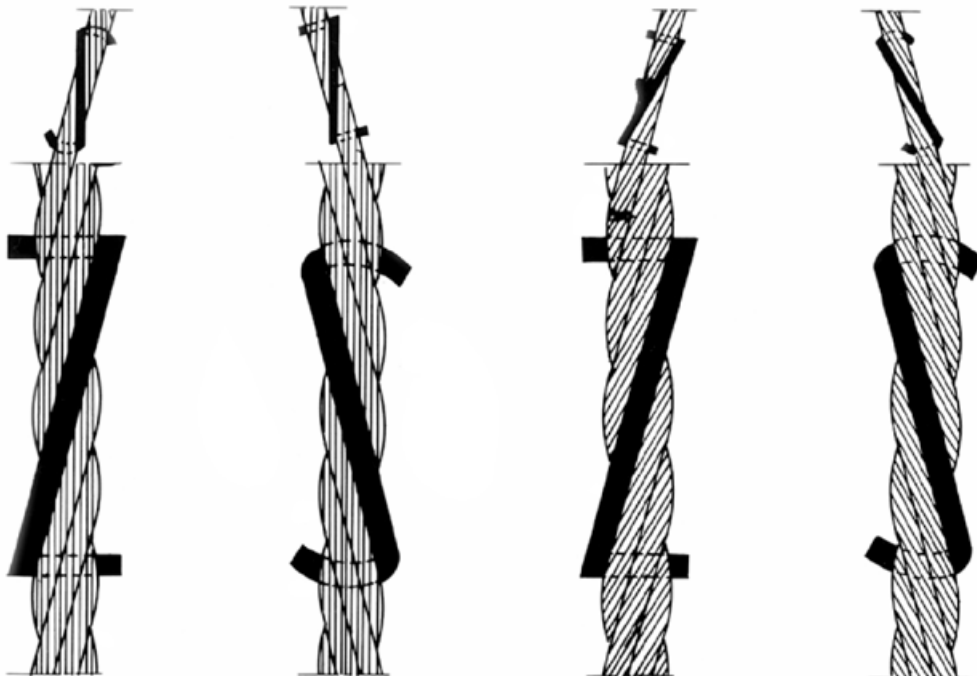

right hand
regular lay

left hand
regular lay

right hand
lang's lay

left hand
lang's lay



4. Cores for wire ropes

Steel

IWRC (Independent Wire Rope Core)

The main core is an independent wire rope, normally having the construction 7×7 , $7 \times 17(S)$

IWSC (Independent Wire Strand Core)

The main core is an independent wire strand, normally having the same construction as the outer strands of the rope.

Fibre

Fibre cores are stranded and comprised either :
Natural fibres such as sisal, hemp, jute, and cotton.

Synthetic fibres such as polyimide, polyethylene, and polypropylene.

5. Preformed ropes

In the preforming process the wires and strands are given their final helical pitch before being laid up into rope. Ropes made in this way show no tendency to untwist when cut.

6. Lubrication

Lubrication reduces internal friction of the wires and strands and protects against corrosion. Grease is applied to all ropes. If special lubricants are required this must be specifically stated at time of ordering.

7. Diameter of wire ropes

The diameter of a wire rope is the diameter of the circle which encloses all of the wires. When measuring wire rope it is important to take the greatest distance of the outer limits of the 'Crowns' of two opposite strands. A measurement across the valleys will result in incorrect lower readings.

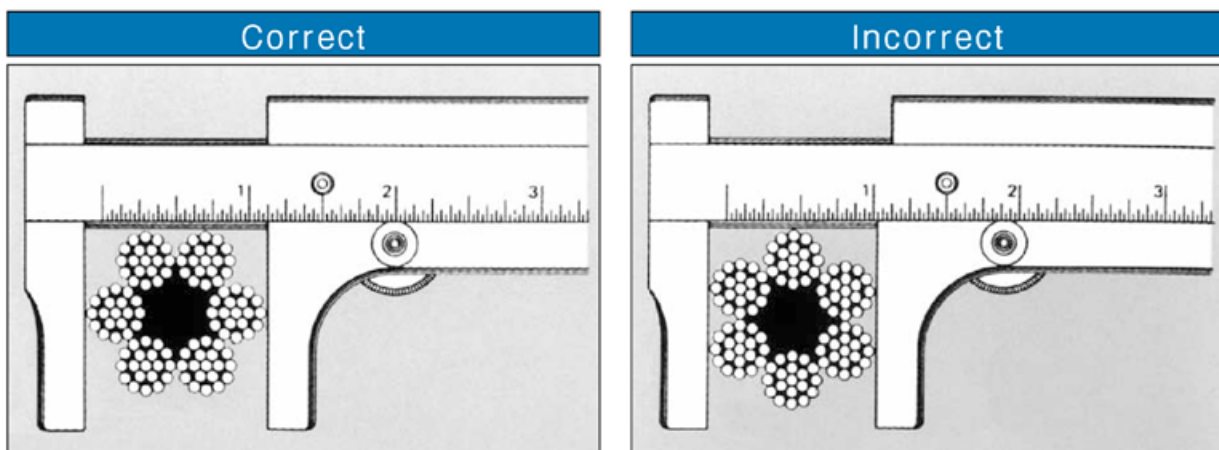

GENERAL INFORMATION



8. SHEAVE AND DRUM

When a rope is bent around the sheave or drum, individual wires in the strand are subjected to bending stress and repeated bending fatigue. To obtain a smooth operation and longer life for the wire rope line, it is necessary to keep the diameter of sheave and drum above the recommendable figures of the Table and to keep the surface of the grooves sharp and smooth.

Minimum Diameter of Sheave and Drum (D=Wire Rope Dia.)

Construction	Min. Dia.	Recommendable Dia.
6 x 7	45 x D	70 x D
6 x 19	30 x D	45 x D
6 x 37	20 x D	30 x D
6 x S(19)	33 x D	50 x D
6 x Fi(25)	26 x D	39 x D
6 x Fi(29)	24 x D	35 x D
8 x S(19)	27 x D	40 x D
18 x 7	35 x D	50 x D

9. SAFETY FACTOR OF WIRE ROPE

It is difficult to fix the safety factor for each type of wire rope to be used for various equipment, as this factor depends not only on the load carried, but also on the speed of rope working, the kinds of fitting used for rope ends, the acceleration and deacceleration, length of rope, the number, size and arrangements of sheave and drums etc. The following safety factors are minimum requirements for safety and economy in the common installation.

Safety Factor of Wire Rope







Purpose	Min.S.F.
Elevator	10
Crane, Hoist Derrick, Sling	6
Guy or Stay, Horizontal Pull or Traction	4
Main Wire of Aerial Rope Way	3

10. MUST AVOID FOR LONGER LIFE OF ROPE

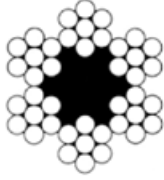
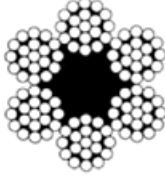
- Twist, Loop or Kink of wire rope.
- Moisture, Dust and Acid or Sulphuric Hume gas.
- Overload.
- Crushing or hammering.
- Severe or reverse bending(S-Bending).
- Too small Sheaves, Drums and Guide Rollers.
- Hard rolling or Sheaves and Rollers.
- Worn Groove, Broken or Soft Sheaves and Rollers.
- Poor or No Lubrication.
- Heat Influence.
- Wrong Fitting and Spooling on the Drum.
- Excessive Fleet Angle.
- Vibration.
- Obstacles, Sand and Grit on the surface of operation line.
- Shock-Too fast start or Stop.

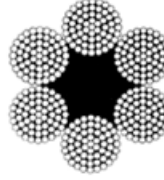
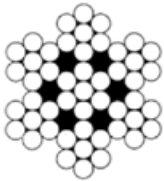
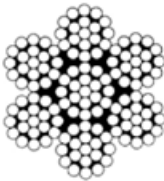
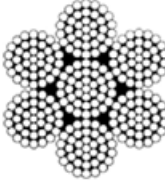
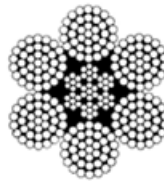
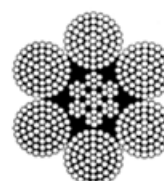
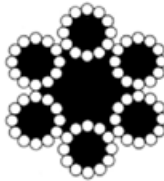
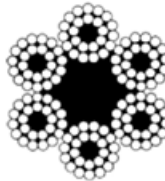
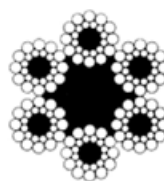
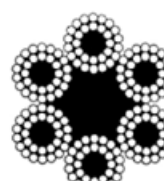
TYPICAL ROPE CONSTRUCTIONS

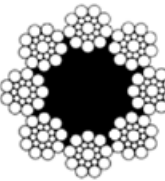
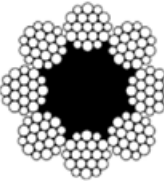
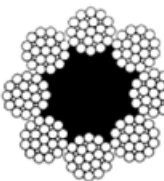
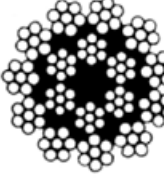
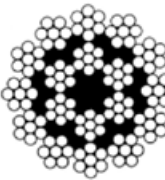
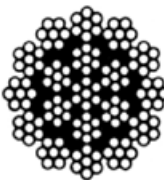
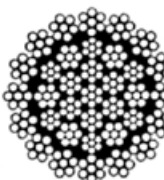
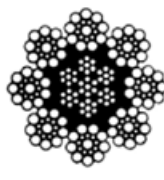

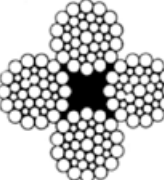
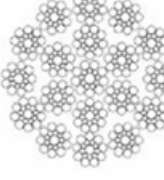
Point Contact Lay Rope				
	6 x 7FC	6 x 19FC	6 x 37FC	6 x 61FC
				
	7 x 7WSC	7 x 19WSC	7 x 37WSC	6 x 37IWRC
				
	6 x 61IWRC			
Marine Rope				
	6 x 12FC	6 x 24FC	6 x S(24)FC	6 x 30FC
Elevator Rope				
	6 x Fi(25)FC	8 x S(19)FC	8 x W(19)FC	8 x Fi(25)FC
Non-Rotating Rope				
	17 x 7FC	18 x 7FC	19 x 7	35 x 7
				
	8 x S(19)IWRC	8 x Fi(25)IWRC	4 x Fi(29)FC	4 x WS(36)FC
				
			19 x 19(S)	





TYPICAL ROPE CONSTRUCTIONS



Linear Contact Lay Rope 6 x19 Class					
	6xS(19)FC	6xS(19)IWRC	6xW(19)FC	6xW(19)IWRC	
Linear Contact Lay Rope 6 x37 Class					
	6xSi(21)FC	6xSi(25)FC	6xSi(25)IWRC	6xWS(26)FC	6xWS(26)IWRC
	6 x Fi(29)FC	6 x Fi(29)IWRC	6 x WS(31)FC	6 x WS(31)IWRC	
	6 x WS(36)FC	6 x WS(36)IWRC	6 x WS(41)FC	6 x WS(41)IWRC	6 x SeS(37)FC
	6 x SeS(37)IWRC	6 x FiS(49)FC	6 x FiS(49)IWRC	6 x FiS(37)IWRC	6 x WS(37)FC
	6 x Fi(33)IWRC	6 x SWS(49)FC	6 x SWS(49)IWRC	6 x SFi(36)FC	6 x SFi(41)IWRC

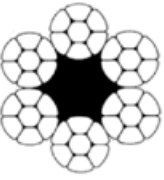
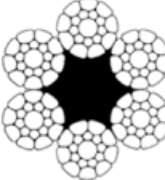
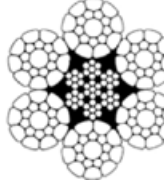
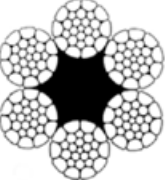
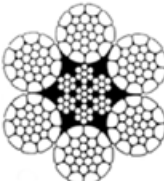
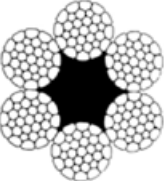
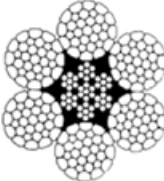
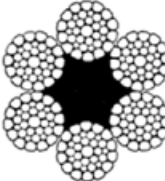
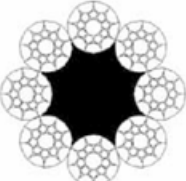
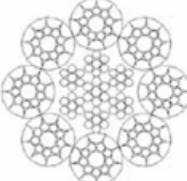
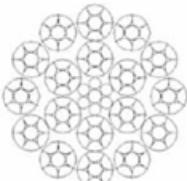
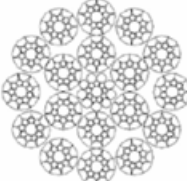
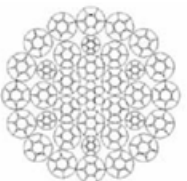
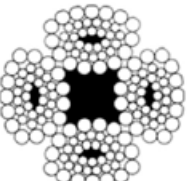
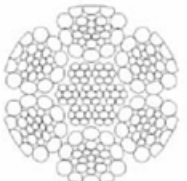
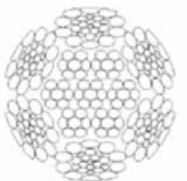
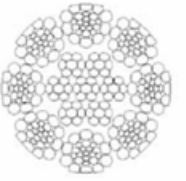

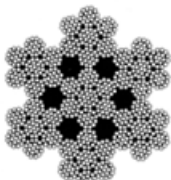

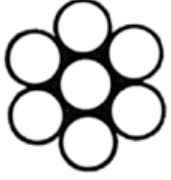
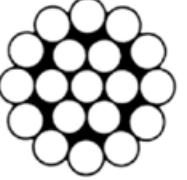
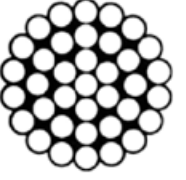



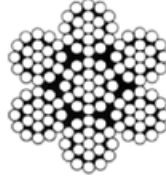

TYPICAL ROPE CONSTRUCTIONS

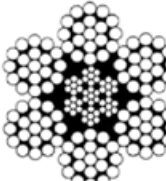

Compact Wire Rope				
	$6 \times 7FC$	$6 \times S(19)FC$	$6 \times S(19)IWRC$	$6 \times WS(26)FC$
				
$6 \times WS(26)IWRC$	$6 \times WS(31)FC$	$6 \times WS(31)IWRC$	$6 \times WS(36)FC$	$6 \times WS(36)IWRC$
				
$8 \times 19(S)C FC$	$8 \times 19(S)C IWRC$	$19 \times 7C$	$19 \times 19(S)C$	$35 \times 7C$
Swaged Wire Rope				
	$4 \times 39(S)S FC$	$6 \times 26(WS)S IWRC$	$6 \times 26(WS)SS IWRC$	$8 \times 26(WS)S IWRC$
Cable Laid Rope			Guard Rope	
	$7 \times 7 \times 7$	$7 \times 7 \times 19$		3×7
Galvanized Steel Strand				
	1×3	1×7	1×19	1×37

TYPICAL ROPE CONSTRUCTIONS

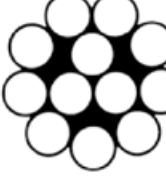
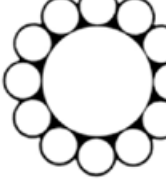
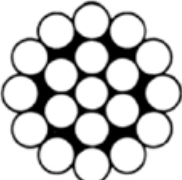

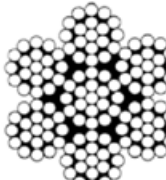
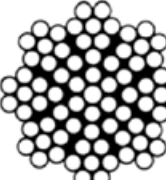
Galvanized Aircraft Cable				
	7 x 7	7 x 19	1 x 19	6 x 19IWRC
P.V.C Coated Cable				
	PVC COATED 7 x 7	PVC COATED 7 x 19	PVC COATED 1 x 19	PVC COATED 6 x 19IWRC
Inner Cable				
	1 x 3	1 x 7	1 x 12	1 x 13
				
	1 x 19	1 x 37	7 x 7	7 x 19
				
				8 x 7+(1 x 19)

“ Authorized by ”

KS	(Ministry of Trade & Industry, Republic of Korea)
JIS	(Ministry of Trade & Industry, Japan)
K.R.	(Korean Register of Shipping)
A.B.S.	(American Bureau of Shipping)
LLOYD'S	(Lloyd's Register of Shipping)
G.L.	(Germanischer Lloyd)
N.K.	(Nippon Kaiji Kyokai)
B.V.	(Bureau Veritas)
D.N.V	(Det Norske Veritas)
R.I.N.A	(Registro Italiano Navale)
ISO 9001	(Lloyd's Register Quality Assurance)
ISO 14001	(Lloyd's Register Quality Assurance)
ISO/TS 16949	(Lloyd's Register Quality Assurance)
API 9A	(American Petroleum Institute)

FEDERAL SPECIFICATION(RR-W-410)



6x7 BRIGHT WIRE ROPE

6x7 +Fiber Core

Rope Dia. (in.)	Approx. Weight/ft. (Lb)	Nominal Breaking Load (Lb)
		Improved Plow Steel
1/4	0.094	5,280
5/16	0.15	8,200
3/8	0.21	11,720
7/16	0.29	15,860
1/2	0.38	20,600
9/16	0.48	26,000
5/8	0.59	31,800
3/4	0.84	45,400
7/8	1.15	61,400
1	1.50	79,400
1 1/8	1.90	99,600
1 1/4	2.34	122,000
1 3/8	2.84	146,200
1 1/2	3.38	172,400

Galvanizing : Strength shall be deducted by 10% from Bright(Uncoated)Wire Ropes.

6x24 GALVANIZED MARINE CABLES

6x24 +7Fiber Core

Rope Dia. (in.)	Approx. Weight/ft. (Lb)	Nominal Breaking Load (Lb)
		Improved Plow Steel
3/8	0.194	9,540
1/2	0.35	16,800
5/8	0.54	26,000
3/4	0.78	37,200
13/16	0.91	43,600
7/8	1.06	50,400
1	1.38	65,600
1 1/16	1.56	73,800
1 1/8	1.75	82,400
1 3/16	1.95	91,800
1 1/4	2.16	101,400
1 3/8	2.61	122,000
1 7/16	2.85	133,000
1 1/2	3.11	144,600
1 5/8	3.64	169,000
1 11/16	3.93	181,800
1 3/4	4.23	195,000
1 13/16	4.53	208,000
1 15/16	5.18	238,000
2	5.52	252,000
2 1/16	5.87	268,000

FEDERAL SPECIFICATION(RR-W-410)



6 x 19 & 6 x 37 CLASSIFICATION WIRE ROPE (SINGLE OPERATION, Bright or Drawn-Galvanized)

6 x 19-26 & 6 x 27-49+Fiber Core or I.W.R.C.

Rope Dia. (in.)	Approx. Weight/ft. (Lb)		Nominal Breaking Load (Lb)		
			Improved Plow Steel		Extra I.P.S.
	F.C.	I.W.R.C.	F.C.	I.W.R.C.	I.W.R.C.
1/4	0.105	0.116	5,480	5,880	6,800
5/16	0.164	0.18	8,520	9,160	10,540
3/8	0.236	0.26	12,200	13,120	15,100
7/16	0.32	0.35	16,540	17,780	20,400
1/2	0.42	0.46	21,400	23,000	26,600
9/16	0.53	0.59	27,000	29,000	33,600
5/8	0.66	0.72	33,400	35,800	41,200
3/4	0.95	1.04	47,600	51,200	58,800
7/8	1.29	1.42	64,400	69,200	79,600
1	1.68	1.85	83,600	89,800	103,400
1 1/8	2.13	2.34	105,200	113,000	130,000
1 1/4	2.63	2.89	129,200	138,800	159,800
1 3/8	3.18	3.50	155,400	167,000	192,000
1 1/2	3.78	4.16	184,000	197,800	228,000
1 5/8	4.44	4.88	214,000	230,000	264,000
1 3/4	5.15	5.67	248,000	266,000	306,000
1 7/8	5.91	6.50	282,000	304,000	348,000
2	6.72	7.39	320,000	344,000	396,000
2 1/8	7.59	8.35	358,000	384,000	442,000
2 1/4	8.51	9.36	400,000	430,000	494,000
2 1/2	10.5	11.6	488,000	524,000	604,000
2 3/4	12.7	14.0	584,000	628,000	722,000
3	15.1	16.6	685,000	740,000	850,000

Galvanizing : Strength shall be deducted by 10% from Bright(Uncoated)Wire Ropes.

FEDERAL SPECIFICATION(RR-W-410)



6 x 37 CLASSIFICATION WIRE ROPE (MULTIPLE OPERATION, Bright or Drawn-galvanized) 6 x 27-49+Fiber Core or I.W.R.C.

Rope Dia. (in.)	Approx. Weight/ft. (Lb)		Nominal Breaking Load (Lb)		
			Improved Plow Steel		Extra I.P.S.
	F.C.	I.W.R.C.	F.C.	I.W.R.C.	I.W.R.C.
1/4	0.105	0.116	5,180	5,560	6,400
5/16	0.164	0.18	8,060	8,660	9,960
3/8	0.236	0.26	11,540	12,400	14,280
7/16	0.32	0.35	15,640	16,820	19,340
1/2	0.42	0.46	20,400	22,000	25,200
9/16	0.53	0.59	25,800	27,800	31,800
5/8	0.66	0.72	31,600	34,000	39,200
3/4	0.95	1.04	45,200	48,600	55,800
7/8	1.29	1.42	61,200	65,800	75,600
1	1.68	1.85	79,600	85,600	98,200
1 1/8	2.13	2.34	100,200	107,800	123,800
1 1/4	2.63	2.89	123,000	132,200	152,200
1 3/8	3.18	3.50	148,200	159,400	183,400
1 1/2	3.78	4.16	175,800	189,000	216,000
1 5/8	4.44	4.88	206,000	222,000	254,000
1 3/4	5.15	5.67	238,000	256,000	292,000
1 7/8	5.91	6.50	272,000	292,000	336,000
2	6.72	7.39	308,000	330,000	380,000
2 1/8	7.59	8.35	346,000	372,000	428,000
2 1/4	8.51	9.36	386,000	414,000	478,000
2 1/2	10.5	11.6	472,000	508,000	584,000
2 3/4	12.7	14.0	568,000	610,000	700,000
3	15.1	16.6	670,000	720,000	828,000
3 1/4	17.7	19.5	780,000	838,000	966,000
3 1/2	20.6	22.7	898,000	966,000	1,110,000

Galvanizing : Strength all be deducted by 10% from Bright(Uncoated)Wire Ropes.

FEDERAL SPECIFICATION(RR-W-410)



8 x 19 CLASSIFICATION ROTATION RESISTANT, WIRE ROPE

8 x 19-36+ Fiber Core or IWRC

Rope Dia. (in.)	Approx. Weight/ft. (Lb)		Nominal Breaking Load (Lb)		
			Improved Plow Steel		Extra I.P.S.
	F.C.	I.W.R.C.	F.C.	I.W.R.C.	I.W.R.C.
1/4	0.098	0.12	4,700	5,160	5,940
5/16	0.15	0.18	7,300	8,020	9,240
3/8	0.22	0.26	10,480	11,520	13,260
7/16	0.30	0.36	14,180	15,600	17,940
1/2	0.39	0.47	18,460	20,200	23,200
9/16	0.50	0.60	23,200	25,600	29,400
5/8	0.61	0.73	28,600	31,400	36,200
3/4	0.88	1.06	41,000	45,000	51,800
7/8	1.20	1.44	55,400	61,000	70,000
1	1.57	1.88	72,000	79,200	91,000
1 1/8	1.99	2.39	90,600	99,600	114,600
1 1/4	2.45	2.94	111,400	122,600	141,000
1 3/8	2.97	3.56	134,200	147,600	169,800
1 1/2	3.53	4.24	158,800	174,600	200,000

Galvanizing : Strength shall be deducted by 10% from Bright(Uncoated)Wire Ropes.

18 x 7 CLASSIFICATION ROTATION RESISTANT, WIRE ROPE

18 x 7 +Fiber Core & Wire Strand Core(19 x 7)

Rope Dia. (in.)	Approx. Weight/ft. (Lb)		Nominal Breaking Load (Lb)	
	Fiber Core	Wire Strand Core	Improved Plow Steel	Extra I.P.S.
3/8	0.24	0.25	11,180	12,300
7/16	0.33	0.35	15,160	16,660
1/2	0.43	0.45	19,700	21,600
9/16	0.55	0.58	24,800	27,200
5/8	0.68	0.71	30,600	33,600
3/4	0.97	1.02	43,600	48,000
7/8	1.32	1.39	59,000	65,000
1	1.73	1.82	76,600	84,400
1 1/8	2.19	2.30	96,400	106,200
1 1/4	2.70	2.84	118,400	130,200
1 3/8	3.27	3.43	142,600	156,800
1 1/2	3.89	4.08	168,800	185,600
1 5/8	4.57	4.80	196,800	216,000
1 3/4	5.30	5.57	228,000	250,000

Galvanizing : Strength shall be deducted by 10% from Bright(Uncoated)Wire Ropes.

A - P - I SPECIFICATION



6 x 7 CLASSIFICATION WIRE ROPE, BRIGHT (UNCOATED)OR DRAWN-GALVANIZED WIRE & GALVANIZED, FIBER CORE

Rope Dia. (in.)	Approx. Weight Per ft (Lb)	Nominal Breaking Load (Lb)			
		Plow Steel		Improved Plow Steel	
		Bright or Drawn Galv'd	Galv'd	Bright or Drawn Galv'd	Galv'd
3/8	0.12	10,200	9,180	11,720	10,540
7/16	0.29	13,800	12,420	15,860	14,280
1/2	0.38	17,920	16,120	20,600	18,540
9/16	0.48	22,600	20,400	26,000	23,400
5/8	0.59	27,800	25,000	31,800	28,600
3/4	0.84	39,600	35,600	45,400	40,800
7/8	1.15	53,400	48,000	61,400	55,200
1	1.50	69,000	62,000	79,400	71,400

19 x 7 CONSTRUCTION WIRE ROPE, BRIGHT(UNCOATED)OR DRAWN-GALVANIZED WIRE, WIRE STRAND CORE

Rope Dia. (in.)	Approx. Weight Per ft (Lb)	Nominal Breaking Load (Lb)	
		Improved Plow Steel	Extra I.P.S
1/2	0.45	19,700	21,600
9/16	0.58	24,800	27,200
5/8	0.71	30,600	33,600
3/4	1.02	43,600	48,000
7/8	1.39	59,000	65,000
1	1.82	76,600	84,400
1 1/8	2.30	96,400	106,200
1 1/4	2.84	118,400	130,200
1 3/8	3.43	142,600	156,800
1 1/2	4.08	168,800	185,600

6 x 19 & 6 x 37 CLASSIFICATION WIRE ROPE, BRIGHT (UNCOATED)OR DRAWN-GALVANIZED WIRE

Rope Dia. (in.)	Approx. Weight Per ft (Lb)		Nominal Breaking Load (Lb)			
			Plow Steel		Improved Plow Steel	
			F.C.	I.W.R.C.	F.C.	I.W.R.C.
1/2	0.42	0.46	18,700	21,400	23,000	26,600
9/16	0.53	0.59	23,600	27,000	29,000	33,600
5/8	0.66	0.72	29,000	33,400	35,800	41,200
3/4	0.95	1.04	41,400	47,600	51,200	58,800
7/8	1.29	1.42	56,000	64,400	69,200	79,600
1	1.68	1.85	72,800	83,600	89,800	103,400
1 1/8	2.13	2.34	91,400	105,200	113,000	130,000
1 1/4	2.63	2.89	112,400	129,200	138,800	159,800
1 3/8	3.18	3.50		155,400	167,000	192,000
1 1/2	3.78	4.16		184,000	197,800	228,000
1 5/8	4.44	4.88		214,000	230,000	264,000
1 3/4	5.15	5.67		248,000	266,000	306,000
1 7/8	5.91	6.50		282,000	304,000	348,000
2	6.72	7.39		320,000	344,000	396,000
2 1/8		8.35			384,000	442,000
2 1/4		9.36			430,000	494,000
2 3/8		10.4			478,000	548,000
2 1/2		11.6			524,000	604,000
2 5/8		12.8			576,000	658,000
2 3/4		14.0			628,000	736,000
2 7/8		15.3			682,000	796,000
3		16.6			740,000	856,000

6 x 19 & 6 x 37 CLASSIFICATION WIRE ROPE, GALVANIZED WIRE

Rope Dia. (in.)	Approx. Weight Per ft (Lb)		Nominal Breaking Load (Lb)			
			Plow Steel		Improved Plow Steel	
			F.C.	I.W.R.C.	F.C.	I.W.R.C.
1/2	0.42	0.46	16,820	19,600	20,600	23,940
9/16	0.53	0.59	21,200	24,200	26,000	30,240
5/8	0.66	0.72	26,000	30,000	32,200	37,080
3/4	0.95	1.04	37,200	42,800	46,000	52,920
7/8	1.29	1.42	50,400	58,000	62,200	71,640
1	1.68	1.85	65,600	75,200	80,800	93,060
1 1/8	2.13	2.34	82,200	94,600	101,600	117,000
1 1/4	2.63	2.89	101,200	116,200	125,000	143,800
1 3/8	3.18	3.50		139,800	150,200	172,800
1 1/2	3.78	4.16		165,600	178,000	205,200
1 5/8	4.44	4.88		192,600	207,000	237,600
1 3/4	5.15	5.67		223,200	239,400	275,400
1 7/8	5.91	6.50		253,800	273,600	313,200
2	6.72	7.39		288,000	309,600	356,400
2 1/8		8.35			345,600	397,800
2 1/4		9.36			387,000	444,600
2 3/8		10.4			430,200	493,200
2 1/2		11.6			471,600	543,600
2 5/8		12.8			518,400	592,200
2 3/4		14.0			565,200	662,400
2 7/8		15.3			613,800	716,400
3		16.6			666,000	770,400

BS 302 GALVANIZED STEEL WIRE ROPES FOR SHIPS



6 x 12 CONSTRUCTION GROUP WITH FIBRE CORES

6 x 12(12/Fibre)FC

Nominal Diameter	Minimum Breaking Force			Minimum Breaking Load			Approximate Mass
	1420 N/mm ² Tensile Grade	1570 N/mm ² Tensile Grade	1770 N/mm ² Tensile Grade	1420 N/mm ² Tensile Grade	1570 N/mm ² Tensile Grade	1770 N/mm ² Tensile Grade	
mm	kN	kN	kN	t	t	t	kg/100m
6	–	–	13.3	–	–	1.36	9.04
7	–	–	18.1	–	–	1.85	12.3
8	19.0	21.0	–	1.94	2.14	–	16.1
9	24.0	26.6	–	2.45	2.71	–	20.3
10	29.7	32.8	–	3.03	3.34	–	25.1
12	42.7	47.3	–	4.35	4.82	–	36.1
14	58.2	64.3	–	5.93	6.55	–	49.2
16	76.0	84.0	–	7.75	8.56	–	64.3

6 x 24 CONSTRUCTION GROUP WITH FIBRE CORES

6 x 24(15/9/Fibre)FC & 6 x 24(12/12/F)FC

Nominal Diameter	Minimum Breaking Force		Minimum breaking load		Approximate Mass
	1420 N/mm ² Tensile Grade	1570 N/mm ² Tensile Grade	1420 N/mm ² Tensile Grade	1570 N/mm ² Tensile Grade	
mm	kN	kN	t	t	kg/100m
8	25.4	28.1	2.59	2.86	19.7
9	32.2	35.6	3.28	3.63	24.9
10	39.8	44.0	4.06	4.49	30.8
11	48.1	53.2	4.90	5.42	37.3
12	57.3	63.3	5.84	6.45	44.4
13	67.2	74.3	6.85	7.57	52.1
14	77.9	86.2	7.94	8.79	60.4
16	102	113	10.4	11.5	78.8
18	129	142	13.1	14.5	99.8
19	144	159	14.7	16.2	111
20	159	176	16.2	17.9	123
22	192	213	19.6	21.7	149
24	229	253	23.3	25.8	177
26	269	297	27.4	30.3	208
28	312	345	31.8	35.2	241
32	407	450	41.5	45.9	315
35	487	539	49.6	54.9	377
36	515	570	52.5	58.1	399
38	574	635	58.5	64.7	445
40	636	703	64.8	71.7	493

BS 302 GALVANIZED STEEL WIRE ROPES FOR SHIPS



6 x 19 CONSTRUCTION GROUP WITH FIBRE MAIN CORE

6 x 19(9/9/1)FC & 6 x 19(12/6/1)FC

Nominal Diameter	Minimum Breaking Force		Minimum Breaking Load		Approximate Mass
	1420 N/mm ² Tensile Grade	1570 N/mm ² Tensile Grade	1420 N/mm ² Tensile Grade	1570 N/mm ² Tensile Grade	
mm	kN	kN	t	t	kg/100m
6	–	19.6	–	2.0	12.5
7	–	26.6	–	2.71	17.0
8	27.9	–	2.84	–	22.1
10	43.6	–	4.44	–	34.6
12	62.8	–	6.40	–	49.8
14	85.4	–	8.71	–	67.8
16	112	–	11.4	–	88.6
18	141	–	14.4	–	112
20	174	–	17.7	–	138
22	211	–	21.5	–	167
24	251	–	25.6	–	199

6 x 37 CONSTRUCTION GROUP WITH FIBRE MAIN CORE

6 x 37(18/12/6/1)FC

Nominal Diameter	Minimum Breaking Force		Minimum Breaking Load		Approximate Mass
	1420 N/mm ² Tensile Grade	1570 N/mm ² Tensile Grade	1420 N/mm ² Tensile Grade	1570 N/mm ² Tensile Grade	
mm	kN	kN	t	t	kg/100m
20	168	185	17.1	18.9	138
22	203	224	20.7	22.8	167
24	241	267	24.6	27.2	199
26	283	313	28.8	31.9	234
28	328	363	33.4	37.0	271
32	429	474	43.7	48.3	354
36	543	600	55.4	61.2	448
40	670	741	68.3	75.5	554
44	811	897	82.7	91.4	670
48	965	1067	98.4	109	797
52	1133	1252	115	128	936
56	1314	1452	134	148	1085
60	1508	1667	154	170	1246
64	1716	1897	175	193	1417
68	1937	2142	197	218	1600
72	2172	2401	221	245	1794

BS 302 WIRE ROPES FOR CRANES, EXCAVATORS AND GENERAL ENGINEERING PURPOSES



6 x 19 AND 6 x 36 CONSTRUCTION GROUPS

Nominal Diameter	Minimum Breaking Force (1770 N/mm ² Tensile Grade)		Minimum Breaking Force (1770 N/mm ² Tensile Grade)		Approximate Mass	
	Fibre Cored	Steel Cored	Fibre Cored	Steel Cored	Fibre Cored	Steel Cored
mm	kN	kN	t	t	kg/100m	kg/100m
6	21.0	22.7	2.14	2.32	12.9	14.3
7	28.6	30.9	2.92	3.15	17.7	19.5
8	37.4	40.3	3.81	4.11	23.1	25.5
9	47.3	51.0	4.82	5.20	29.2	32.2
10	58.4	63.0	5.95	6.42	36.1	39.8
11	70.7	76.2	7.21	7.77	43.7	48.2
12	84.1	90.7	8.57	9.25	52.0	57.3
13	98.7	106	10.1	10.8	61.0	67.3
14	114	124	11.6	12.6	70.8	78.0
16	150	161	15.3	16.4	92.4	102
18	189	204	19.3	20.8	117	129
19	211	227	21.5	23.1	130	144
20	234	252	23.9	25.7	144	159
22	283	305	28.8	31.1	175	193
24	336	363	34.3	37.0	208	229
26	395	426	40.3	43.4	244	269
28	458	494	46.7	50.4	283	312
32	598	645	61.0	65.7	370	408
35	716	772	73.0	78.7	442	488
36	757	817	77.2	83.3	468	516
38	843	910	85.9	92.8	521	575
40	935	1008	95.3	103	578	637
44	1131	1220	115	124	699	771
48	1346	1452	137	148	832	917
52	1579	1704	161	174	976	1076
54	1703	1837	174	187	1053	1161
56	1832	1976	187	201	1132	1248
60	2103	2268	214	231	1300	1433

NOTE 1. 3mm to 8mm rope is not available in the 6 x 36 construction group.

NOTE 2. 56mm and 60mm ropes are only available in the 6 x 36 construction group.

NOTE 3. The values for 3, 4, 5 and 6mm ropes are based on 6 x 19 cross-lay construction.

BS 302 WIRE ROPES FOR CRANES, EXCAVATORS AND GENERAL ENGINEERING PURPOSES



17 x 7 AND 18 x 7 CONSTRUCTION GROUPS WITH FIBRE OR STEEL CORE

17 x 7(6/1)Multi-strand & 18 x 7 Multi-strand

Nominal Diameter	Minimum Breaking Force (1770 N/mm ² Tensile Grade)	Minimum Breaking Load (1770 N/mm ² Tensile Grade)	Approximate Mass (Fibre Cored)
mm	kN	t	kg/100m
6	20.9	2.13	14.0
7	28.4	2.90	19.1
8	37.2	3.79	25.0
9	47.0	4.79	31.6
10	58.1	5.92	39.0
11	70.2	7.16	47.2
12	83.6	8.52	56.2
13	98.1	10.0	65.9
14	114	11.6	76.4
16	149	15.2	99.8
18	188	19.2	126
19	210	21.4	141
20	232	23.6	156
22	281	28.6	189
24	334	34.0	225
26	392	40.0	264

34 x 7 CONSTRUCTION GROUP WITH FIBRE OR STEEL CORE

34 x 7 FC Multi-strand & 36 x 7 Multi-strand

Nominal Diameter	Minimum Breaking Force (1770 N/mm ² Tensile Grade)	Minimum Breaking Force (1770 N/mm ² Tensile Grade)	Approximate Mass
mm	kN	t	kg/100m
16	144	14.7	99.8
18	182	18.6	126
19	203	20.7	141
20	225	22.9	156
22	272	27.7	189
24	324	33.0	225
26	380	38.7	264
28	441	45.0	306
32	576	58.7	399
35	690	70.3	478
36	729	74.3	505
38	813	82.9	563
40	901	91.8	624



JIS G 3525 WIRE ROPE

Dia. of Wire Rope (mm)	6 x 7 FC			Approx. Weight (kg/m)
	Breaking Load(ton)			
	Galvanized	Bright or Drawn galv.	Bright	
	Grade G	Grade A	Grade B	
3.15	0.53	0.60	0.66	0.037
4	0.86	0.97	1.06	0.059
5	1.35	1.52	1.66	0.093
6.3	2.14	2.41	2.63	0.147
8	3.45	3.88	4.24	0.237
9	4.36	4.91	5.37	0.300
10	5.38	6.06	6.62	0.371
11.2	6.75	7.61	8.31	0.465
12.5	8.41	9.48	10.4	0.580
14	10.6	11.9	13.0	0.727
16	13.8	15.5	17.0	0.950
18	17.4	19.6	21.5	1.20
20	21.5	24.3	26.5	1.48
22.4	27.0	30.4	33.2	1.86
(24)	–	(34.9)	(38.2)	(2.14)
25	33.6	37.9	41.4	2.32
(26)	–	(41.0)	(44.8)	(2.51)
28	42.2	47.5	51.9	2.91
30	48.4	54.6	59.6	3.34
31.5	53.4	60.2	65.7	3.68
33.5	60.4	68.1	74.3	4.16
35.5	67.8	76.4	–	4.67
37.5	75.7	–	–	5.22
40	86.1	–	–	5.93

Dia. of Wire Rope (mm)	6 x 24 FC		Approx. Weight (kg/m)
	Breaking Load(ton)		
	Galvanized	Bright or Drawn galv.	
	Grade G	Grade A	
8	2.99	3.22	0.212
9	3.78	4.07	0.269
10	4.67	5.03	0.332
11.2	5.86	6.31	0.416
(12)	(6.72)	(7.24)	(0.478)
12.5	7.30	7.85	0.519
14	9.15	9.85	0.651
16	12.0	12.9	0.850
18	15.1	16.3	1.08
20	18.7	20.1	1.33
22.4	23.4	25.2	1.67
(24)	(26.9)	–	(1.91)
25	29.2	31.4	2.08
28	36.6	39.4	2.60
30	42.0	45.2	2.99
31.5	46.3	49.9	3.29
33.5	52.4	56.4	3.73
35.5	58.8	63.4	4.18
37.5	65.7	70.7	4.67
40	74.7	80.4	5.31
42.5	84.3	90.8	6.00
45	94.5	102	6.72
47.5	105	113	7.49
50	117	126	8.30



JIS G 3525 WIRE ROPE

6 x 19 FC				
Dia. of Wire Rope (mm)	Breaking Load(ton)			Approx. Weight (kg/m)
	Galvanized	Bright or Drawn galv.	Bright	
	Grade G	Grade A	Grade B	
4	0.82	0.88	0.96	0.058
5	1.28	1.38	1.47	0.091
6.3	2.03	2.19	2.33	0.144
8	3.28	3.53	3.76	0.233
9	4.15	4.46	4.76	0.295
10	5.12	5.51	5.88	0.364
11.2	6.42	6.91	7.37	0.457
(12)	(7.37)	(7.93)	(8.46)	(0.524)
12.5	8.00	8.61	9.18	0.569
14	10.0	10.8	11.5	0.713
16	13.1	14.1	15.0	0.932
18	16.6	17.8	19.0	1.18
20	20.5	22.0	23.5	1.46
22.4	25.7	27.6	29.5	1.83
25	32.0	34.4	36.7	2.28
28	40.1	43.2	46.1	2.85
30	46.1	49.6	52.9	3.28

6 x 37 FC				
Dia. of Wire Rope (mm)	Breaking Load(ton)			Approx. Weight (kg/m)
	Galvanized	Bright or Drawn galv.	Bright	
	Grade G	Grade A	Grade B	
6.3	2.00	2.15	2.29	0.143
8	3.22	3.47	3.70	0.23
9	4.08	4.39	4.68	0.291
10	5.03	5.42	5.78	0.359
11.2	6.31	6.79	7.24	0.451
(12)	(7.25)	(7.80)	(8.32)	(0.517)
12.5	7.86	8.46	9.02	0.561
14	9.86	10.6	11.3	0.704
16	12.9	13.9	14.8	0.92
18	16.3	17.5	18.7	1.16
20	20.1	21.7	23.1	1.44
22.4	25.3	27.2	29.0	1.80
(24)	(29.0)	—	—	(2.07)
25	31.5	33.8	36.1	2.25
28	39.5	42.5	45.3	2.82
30	45.3	48.7	52.0	3.23
31.5	49.9	53.7	57.3	3.57
33.5	56.5	60.8	64.8	4.03
35.5	63.4	68.3	72.8	4.53
37.5	70.8	76.2	81.2	5.05
40	80.5	86.7	92.4	5.75
42.5	90.9	97.8	104	6.49
45	102	110	117	7.28
47.5	114	122	130	8.11



JIS G 3525 WIRE ROPE

Dia. of Wire Rope (mm)	6 x S(19)FC 6 x Fi(25)FC			6 x W(19)FC 6 x WS(26)FC			Approx. Weight (kg/m)
	Breaking Load(ton)			Bright or Drawn galv. Grade A	Bright Grade B	Approx. Weight (kg/m)	
	Galvanized Grade G	Bright or Drawn galv. Grade A	Bright Grade B				
4	0.81	0.89	0.95			0.062	
5	1.26	1.39	1.48			0.096	
6.3	2.00	2.20	2.35			0.153	
8	3.23	3.55	3.79			0.247	
9	4.08	4.50	4.80			0.312	
10	5.04	5.55	5.92			0.386	
11.2	6.32	6.97	7.43			0.484	
(12)	(7.26)	(8.00)	(8.52)			(0.556)	
12.5	7.88	8.68	9.25			0.603	
14	9.88	10.9	11.6			0.756	
16	12.9	14.2	15.2			0.988	
18	16.3	18.0	19.2			1.25	
20	20.2	22.2	23.7			1.54	
22.4	25.3	27.9	29.7			1.94	
25	31.5	34.7	37.0			2.41	
28	39.5	43.5	46.4			3.02	
30	45.4	50.0	53.3			3.47	
31.5	50.0	55.1	58.7			3.83	
33.5	56.6	62.3	66.4			4.33	
35.5	63.5	70.0	74.6			4.86	
37.5	70.9	78.1	83.3			5.43	
40	80.6	88.9	94.7			6.17	
42.5	91.0	100	107			6.97	
45	102	112	120			7.81	
47.5	114	125	134			8.70	
50	126	139	148			9.65	
53	142	156	166			10.8	
56	158	174	186			12.1	
60	181	200	213			13.9	

Dia. of Wire Rope (mm)	6 x S(19)IWRC 6 x Fi(25)IWRC			6 x W(19)IWRC 6 x WS(26)IWRC			Approx. Weight (kg/m)
	Breaking Load(ton)			Bright or Drawn galv. Grade A	Bright Grade B	Approx. Weight (kg/m)	
	Galvanized Grade G	Bright or Drawn galv. Grade A	Bright Grade B				
10	6.34		6.75			0.430	
11.2	7.95		8.47			0.539	
12.5	9.90		10.5			0.672	
14	12.4		13.2			0.843	
16	16.2		17.3			1.10	
18	20.5		21.9			1.39	
20	25.4		27.0			1.72	
22.4	31.8		33.9			2.16	
25	39.6		42.2			2.69	
28	49.7		52.9			3.37	
30	57.1		60.7			3.87	
31.5	62.9		67.0			4.27	
33.5	71.1		75.7			4.83	
35.5	79.9		85.1			5.42	
37.5	89.1		94.9			6.05	
40	101		108			6.88	
42.5	114		122			7.77	
45	128		137			8.71	
47.5	143		152			9.70	
50	158		169			10.8	
53	178		190			12.1	
56	199		212			13.5	
60	228		243			15.5	



JIS G 3525 WIRE ROPE

Dia. of Wire Rope (mm)	Breaking Load(ton)			Approx. Weight (kg/m)
	Galvanized	Bright or Drawn galv.	Bright	
	Grade G	Grade A	Grade B	
	6 x Fi(29)FC 6 x WS(36)FC 6 x WS(41)FC 6 x SeS(37)FC			
8	3.29	3.63	3.87	0.253
9	4.17	4.59	4.89	0.321
10	5.14	5.67	6.04	0.396
11.2	6.45	7.11	7.58	0.496
12.5	8.04	8.86	9.44	0.618
14	10.1	11.1	11.8	0.776
16	13.2	14.5	15.5	1.01
18	16.7	18.4	19.6	1.28
20	20.6	22.7	24.2	1.58
22.4	25.8	28.4	30.3	1.99
25	32.2	35.4	37.8	2.47
28	40.3	44.4	47.4	3.10
30	46.3	51.0	54.4	3.56
31.5	51.1	56.3	59.5	3.93
33.5	57.7	63.6	67.8	4.44
35.5	64.8	71.4	76.1	4.99
37.5	72.4	79.7	84.9	5.57
40	82.3	90.7	96.6	6.33
42.5	92.9	102	109	7.15
45	104	115	122	8.01
47.5	116	128	136	8.93
50	129	142	151	9.90
53	145	159	170	11.1
56	161	178	189	12.4
60	185	204	217	14.2

Dia. of Wire Rope (mm)	Breaking Load(ton)		Approx. Weight (kg/m)
	Bright or Drawn galv.	Bright	
	Grade A	Grade B	
	6 x Fi(29)IWRC 6 x WS(36)IWRC 6 x WS(41)IWRC 6 x SeS(37)IWRC		
10	6.49	6.90	0.44
11.2	8.14	8.66	0.552
12.5	10.1	10.8	0.688
14	12.7	13.5	0.863
16	16.6	17.7	1.13
18	21.0	22.4	1.43
20	25.9	27.6	1.76
22.4	32.5	34.6	2.21
25	40.5	43.2	2.75
28	50.9	54.1	3.45
30	58.4	62.1	3.96
31.5	64.4	68.5	4.37
33.5	72.8	77.5	4.94
35.5	81.8	87.0	5.55
37.5	91.2	97.1	6.19
40	104	110	7.04
42.5	117	125	7.95
45	131	140	8.91
47.5	146	156	9.93
50	162	173	11.0
53	182	194	12.4
56	203	217	13.8
60	234	249	15.8



JIS G 3525 WIRE ROPE

19 x 7					
Dia. of Wire Rope (mm)	Breaking Load(ton)				Approx. Weight (kg/m)
	Galvanized	Bright or Drawn galv.		Bright	
		Grade G	Grade A		
6.00	1.96	2.16	2.36	2.55	0.153
6.30	2.16	2.38	2.60	2.81	0.168
8.00	3.49	3.84	4.19	4.54	0.272
9.00	4.41	4.86	5.30	5.74	0.344
9.50	4.92	5.41	5.90	6.40	0.383
10.0	5.45	6.00	6.54	7.09	0.425
11.2	6.83	7.52	8.21	8.89	0.533
12.0	7.85	8.64	9.42	10.2	0.611
12.6	8.65	9.52	10.4	11.3	0.674
13.0	9.21	10.1	11.1	12.0	0.717
14.0	10.7	11.8	12.8	13.9	0.832
14.3	11.1	12.3	13.4	14.5	0.868
15.0	12.3	13.5	14.7	15.9	0.955
16.0	13.9	15.4	16.7	18.1	1.087
17.5	16.7	18.4	20.0	21.7	1.300
18.0	17.7	19.4	21.2	23.0	1.375
19.0	19.7	21.6	23.6	25.6	1.532
20.0	21.8	24.0	26.2	28.3	1.698
21.0	24.0	26.4	28.9	31.3	1.872
22.4	27.3	30.1	32.8	35.6	2.130
24.0	31.4	34.5	37.7	40.8	2.445
25.0	34.1	37.5	40.9	44.3	2.653
25.4	35.1	38.7	42.2	45.7	2.739
26.0	36.8	40.5	44.2	47.9	2.870
28.0	42.7	47.0	51.3	55.6	3.328
28.6	44.6	49.1	53.5	58.0	3.472
30.0	49.0	54.0	58.9	63.8	3.821
32.0	55.8	61.4	67.0	72.6	4.347
34.0	63.0	69.3	75.6	81.9	4.907
35.0	66.7	73.5	80.1	86.8	5.200
36.0	70.6	77.7	84.8	91.9	5.502
38.0	78.7	86.6	94.5	102	6.130
40.0	87.2	96.0	105	113	6.792

35 x 7				
Dia. of Wire Rope (mm)	Breaking Load(ton)			Approx. Weight (kg/m)
	Bright or Drawn galv.		Bright	
	Grade A	Grade B		
16.0	16.4	17.9	19.4	1.14
17.5	19.6	21.4	23.2	1.36
18.0	20.7	22.6	24.5	1.44
19.0	23.1	25.2	27.3	1.61
20.0	25.6	27.9	30.3	1.78
21.0	28.2	30.8	33.4	1.96
22.4	32.1	35.0	38.0	2.23
24.0	36.9	40.2	43.6	2.56
25.0	40.0	43.7	47.3	2.78
25.4	41.3	45.1	48.8	2.87
26.0	43.3	47.2	51.2	3.01
28.0	50.2	54.8	59.3	3.49
28.6	52.4	57.1	61.9	3.64
30.0	57.6	62.9	68.1	4.00
32.0	65.6	71.5	77.5	4.55
34.0	74.0	80.7	87.5	5.14
35.0	78.4	85.6	92.7	5.45
36.0	83.0	90.5	98.1	5.76



UNIQUE ROPE

YOUNG HEUNG'S "UNIQUE ROPE" BRAND FOR CRANES

WHAT'S "UNIQUE ROPE" ?

YOUNG HEUNG'S "Unique Rope" is manufactured with superior materials, each perfectly designed to create the finest quality products. "Unique Rope" is finished through a special forming process after closing the wire rope strands.

Each strand is formed into a triangular shape and the outer surface is abraded.

Generally, it's well known that wire ropes tend to spin or rotate under load.

This is inherent to the nature of standard types of ropes due to the variance of the helixes of the individual wires and strands.

YOUNG HEUNG'S "Unique Rope" was developed to meet the special demand of various kinds of cranes.

WHY IS "UNIQUE ROPE" NON-ROTATING?

The non-rotating property of wire rope is represented by the rotation index I_r which is expressed by the following formula :

$$I_r = |T_r - n \cdot t_s| / s$$

Where

- T_r is the rotation torque of rope
- T_s is the rotation torque of strand
- n is the number of strands
- s is the resistance to rotation

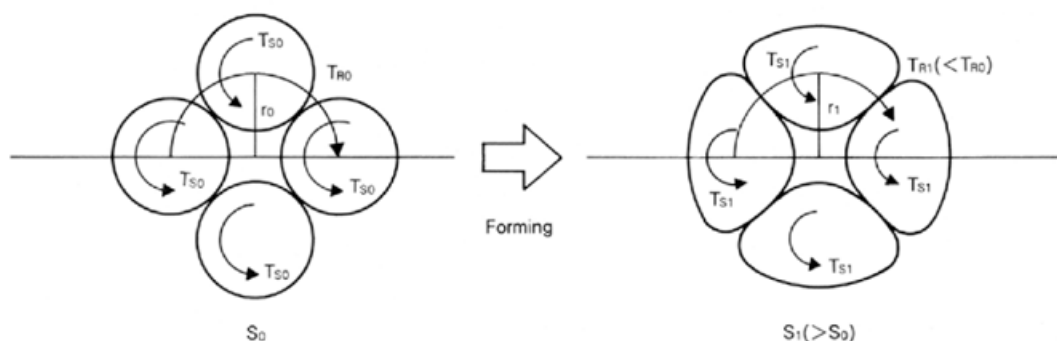

by the special procedures used in our production.

We have virtually eliminated the traditional problem of the helix phenomenon.



UNIQUE ROPE

CHARACTERISTICS :

HIGHER BREAKING STRENGTH

The breaking strength of unique rope is higher than that of 6-strand ropes of equivalent diameter ; Hence the margin of safety is higher.

LESS CRUSHING

Unique rope with stands abrasion and fits the grooves of drum or sheave with a low friction level.

This improves life span of the rope, especially in applications which have multiple layers on the drums.

SUPERIOR NON-ROTATING

The inherent nature to spin or rotate under load, is controlled to a minimum by “Unique Rope” which has been confirmed through many fields tests.

DURABILITY

The smooth surface of this rope reduces and distributes pressure on itself as well as the sheave and drum.

Standard Diameter and Breaking Load

4 x SeS(39)+FC									
Diameter of Rope (mm)	Sectional Area (mm ²)	Breaking Load						Approx. Weight (kg/m)	
		S Grade		H Grade		SH Grade			
		kN	ton	kN	ton	kN	ton		
8	28.6	37.5	3.83	40.9	4.10	44.3	4.52	0.257	
9	36.2	47.5	4.84	51.8	5.28	56.1	5.72	0.326	
10	44.7	58.6	5.98	63.9	6.52	69.2	7.06	0.402	
11.2	56.1	73.6	7.50	80.2	8.18	86.8	8.86	0.504	
12	64.4	84.4	8.61	92.1	9.39	99.7	10.2	0.579	
12.5	69.8	91.6	9.34	99.9	10.2	108	11.0	0.628	
14	87.6	115	11.7	125	12.8	136	13.8	0.788	
16	114	150	15.3	164	16.7	177	18.1	1.03	
18	145	190	19.4	207	21.1	224	22.9	1.30	
19	161	212	21.6	231	23.5	250	25.5	1.45	
20	179	235	23.9	256	26.1	277	28.2	1.61	
22	216	284	28.9	309	31.6	335	34.2	1.95	
22.4	224	294	30.0	321	32.7	347	35.4	2.20	
24	257	338	34.4	368	37.6	399	40.7	2.32	
25	279	367	37.4	400	40.8	433	44.1	2.51	
26	302	396	40.4	432	44.1	468	47.7	2.72	
28	350	460	46.9	501	51.1	543	55.4	3.15	
30	402	528	53.8	575	58.7	623	63.5	3.62	
31.5	444	582	59.3	634	64.7	687	70.1	3.99	
32	458	600	61.2	655	66.8	709	72.3	4.12	
33.5	502	658	67.1	718	73.2	777	79.2	4.51	
34	517	678	69.1	739	75.4	800	81.6	4.65	
35.5	563	739	75.4	806	82.2	872	89.0	5.07	
38	645	846	86.3	923	94.2	999	102	5.75	
40	714	937	95.6	1,020	104	1,100	112	6.37	
44	563	1,130	115	1,230	125	1,290	132	7.71	
48	1,027	1,340	136	1,460	149	1,550	158	9.17	



SWAGED WIRE ROPE

OUR CUSTOMERS SAY IT BEST! SWAGED WIRE ROPE IS THE BEST!!

Our Swaged wire ropes were developed to meet the quality demands of logging operations but can be adapted for other uses.

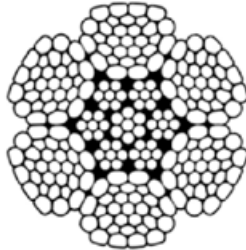

SWAGED ROPES
1" B/L = 123,000Lbs

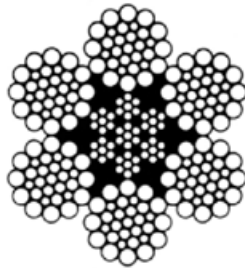

REGULAR ROUND ROPES
1" B/L = 89,800Lbs

Swaged wire ropes could be used wherever increased strengths or lasting longer service life are desired.

Our swaged wire ropes are used for logging operations especially.

Some advantages of our swaged wire rope are :

- Higher strength than standard ropes
- Greater durable resistance and longer life
- Resistance to crushing

This really is our best product confirmed by our clients

We have been continuously striving to provide the most competitive rope for your specific operation.

We'll continue to make improvements and research our conventional wire rope.

Imagine the powerful and positive impression the "Swaged Wire Rope" gives your business.

If you have any questions, please feel to contact us for additional information.

CHARACTERISTICS :

STRENGTH

Our Swaged wire rope increases the working load from greater surface area on outer wires and a compact cross-section with minimum voids, also a higher strength than an unswayed wire rope of comparable size and diameter.

DURABILITY

The smooth surface of a rotary swaged rope reduces and distributes pressures on the rope, as well as the sheaves and drum, and results in longer life.

CRUSHING

The rope's compactness reduces the amount of internal voids so that it provides a much higher resistance to crushing.

This improves the service life of the rope, especially in those applications which have multiple layers on the drums.



SWAGED WIRE ROPE

Swaged Wire Rope 6 x 25(Fi)S+IWRC, 6 x 26(WS)S+IWRC, 6 x 29(Fi)S+IWRC 6 x 31(WS)S+IWRC, 6 x 36(WS)S+IWRC, 6 x 41(WS)S+IWRC						
Dia of Wire Rope (in)	NORMAL TYPE			SUPER TYPE		
	Breaking Load(Lbs)		Approx. Weight (Lb/ft)	Breaking Load(Lbs)		Approx. Weight (Lb/ft)
	Grade IPS	Grade EIPS		Grade IPS	Grade EIPS	
3/8	16,100	18,500	0.330	17,700	20,400	0.350
7/16	21,100	24,300	0.420	23,100	26,600	0.460
1/2	27,700	31,800	0.550	30,300	34,800	0.610
9/16	34,800	40,000	0.710	38,100	43,800	0.780
5/8	42,600	49,000	0.870	47,000	54,000	0.965
11/16	51,300	59,000	1.05	56,500	65,000	1.16
3/4	60,900	70,000	1.25	67,000	77,000	1.38
7/8	82,600	95,000	1.70	90,400	104,000	1.87
1	107,000	123,000	2.22	115,700	133,000	2.44
1-1/8	133,000	153,000	2.81	138,300	159,000	3.09
1-1/4	161,700	186,000	3.47	169,600	195,000	3.82
1-3/8	193,000	222,000	4.20	203,500	234,000	4.62
1-1/2	230,000	264,500	5.00	242,500	279,000	5.51
1-5/8	270,000	310,000	5.86	285,000	327,000	6.47
1-3/4	314,000	360,000	6.80	331,000	380,000	7.51

Swaged Wire Rope 6 x 25(Fi)S+IWRC, 6 x 26(WS)S+IWRC, 6 x 29(Fi)S+IWRC 6 x 31(WS)S+IWRC, 6 x 36(WS)S+IWRC, 6 x 41(WS)S+IWRC						
Dia of Wire Rope (mm)	NORMAL TYPE			SUPER TYPE		
	Breaking Load(ton)		Approx. Weight (kg/m)	Breaking Load(ton)		Approx. Weight (kg/m)
	Grade B	Grade C		Grade B	Grade C	
10	8.13	9.03	0.520	8.89	9.9	0.569
12	11.7	12.9	0.749	12.8	14.2	0.819
14	16.0	17.7	1.01	17.5	19.3	1.11
16	20.8	23.1	1.33	22.7	25.3	1.45
18	26.4	29.3	1.68	28.8	32.0	1.84
20	32.6	36.1	2.08	35.6	39.4	2.27
22.4	40.8	45.3	2.61	44.6	49.5	2.86
24	46.8	52.0	3.00	51.2	56.9	3.28
26	55.1	61.0	3.52	60.2	66.7	3.85
28	63.8	70.8	4.08	69.7	77.4	4.46
30	73.2	81.2	4.68	80.0	88.7	5.12
31.5	80.7	89.5	5.17	88.2	97.9	5.65
33.5	91.4	101.3	5.84	99.8	110.7	6.39
35.5	102.6	113.7	6.56	112.1	124.3	7.17
38.0	117.0	127.0	7.51	127.0	137.0	8.21
40.0	130.0	141.0	8.32	141.0	151.0	9.10
44.0	157.3	168.0	10.1	170.0	182.0	11.0



COMPACT WIRE ROPE

1. THIS COMPACT STRAND WIRE ROPE;

Wire rope consists of wire classified into point contact lay rope & linear contact rope per the condition of wire contact. The rope improves point contact to linear contact.

Development of compacted strand rope allows the most improved linear contact. The rope's life is longer and dramatically extends its' usage.

In accordance with this special need, Young Heung installed a new modernized facility and developed the compacted strand rope. Since then, we have entered into mass production and supply to export markets with Young Heung's accumulated qualified technology.

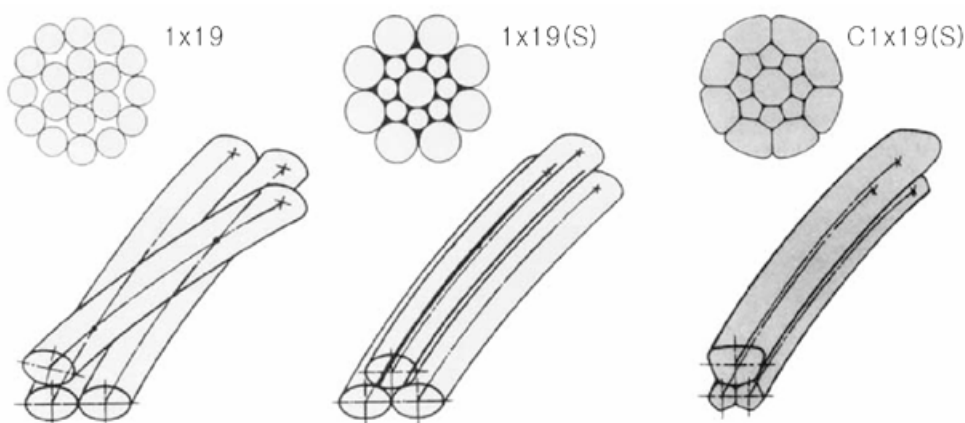

2. SPECIALITY

With superiority on breaking load, endurance, wear resistance, the longer life cycle enables to raise the production & production proficiency

- ◆ **Higher Breaking Load**
Breaking load is higher than normal rope
- ◆ **Superior Endurance**
The wire, consisting of strand which are elaborately compacted, improves the endurance compared to standard ropes.
- ◆ **Superior Wear Resistance**
The flattened strand surface enables less abrasion as the rope contacts drum or sheave.
- ◆ **Flexibility**
Though the flexibility is less than normal rope but this does not cause a problem considering the application of compact rope.

3. APPLICATION

The rope's application is similar to normal ropes, but this "Compact" strand rope is very highly recommended in the area of mining, fishing or construction.



COMPACT WIRE ROPE

Compact Wire Rope 6 x 19(S)C+FC, 6 x 26(WS)C+FC						
Dia.of Wire Rope (mm)	Dia.of Wire Rope (in.)	Breaking Load(ton)			Approx. Weight (kg/m)	Approx. Weight (Lb/ft)
		Grade A	Grade B	Grade C		
10	—	6.41	6.99	7.57	0.413	0.278
11	7/16	7.76	8.46	9.16	0.500	0.336
12	—	9.17	10.0	10.9	0.594	0.399
13	1/2	10.8	11.7	12.8	0.697	0.468
14	9/16	12.7	13.9	15.0	0.820	0.551
16	5/8	16.4	17.9	19.4	1.06	0.712
18	11/16	20.7	22.6	24.5	1.34	0.90
19	3/4	23.1	25.2	27.3	1.49	1.00
20	13/16	25.6	27.9	30.3	1.65	1.11
22	7/8	31.0	33.8	36.6	2.00	1.34
24	15/16	36.9	40.2	43.6	2.38	1.60
26	1	42.6	46.5	50.4	2.75	1.85
28	1+1/8	50.9	55.6	60.2	3.28	2.20
30	—	57.7	62.9	68.2	3.71	2.49
32	1+1/4	65.6	71.6	77.6	4.22	2.84
34	—	74.1	80.8	87.6	4.77	3.21
35	1+3/8	78.5	85.6	92.8	5.05	3.39
36	—	83.1	90.6	98.2	5.35	3.60
38	1+1/2	92.6	101	109	5.96	4.01
40	—	102	111	121	6.60	4.44

Compact Wire Rope 6 x 19(S)C+IWRC, 6 x 26(WS)C+IWRC						
Dia.of Wire Rope (mm)	Dia.of Wire Rope (in.)	Breaking Load(ton)			Approx. Weight (kg/m)	Approx. Weight (Lb/ft)
		Grade A	Grade B	Grade C		
10	—	7.13	7.78	8.42	0.453	0.304
11	7/16	8.63	9.41	10.19	0.548	0.368
12	—	10.3	11.2	12.1	0.652	0.438
13	1/2	12.1	13.1	14.2	0.765	0.514
14	9/16	14.1	15.4	16.7	0.90	0.605
16	5/8	18.4	19.9	21.5	1.16	0.780
18	11/16	23.3	25.2	27.3	1.47	0.988
19	3/4	26.0	28.1	30.4	1.64	1.10
20	13/16	28.8	31.1	33.7	1.81	1.22
22	7/8	34.9	37.6	40.7	2.19	1.47
24	15/16	41.5	44.8	48.5	2.61	1.75
26	1	48.0	51.7	56.1	3.01	2.02
28	1+1/8	57.3	61.8	67.0	3.60	2.42
30	—	64.9	70.0	75.8	4.07	2.74
32	1+1/4	73.9	79.6	86.3	4.63	3.11
34	—	83.4	89.9	97.4	5.23	3.51
35	1+3/8	88.4	95.3	103.2	5.54	3.72
36	—	93.5	100	109	5.86	3.94
38	1+1/2	104	112	121	6.53	4.39
40	—	115	124	134	7.24	4.87



COMPACT WIRE ROPE

Compact Wire Rope 6 x 31(WS)C+FC, 6 x 36(WS)C+FC, 6 x 41(WS)C+FC						
Dia.of Wire Rope (mm)	Dia.of Wire Rope (in.)	Breaking Load(ton)			Approx. Weight (kg/m)	Approx. Weight (Lb/ft)
		Grade A	Grade B	Grade C		
10	—	6.5	7.1	7.7	0.424	0.285
11	7/16	7.9	8.6	9.4	0.513	0.345
12	—	9.3	10.2	11.0	0.611	0.411
13	1/2	10.9	12.0	12.9	0.717	0.482
14	9/16	12.9	14.1	15.3	0.843	0.566
16	5/8	16.6	18.1	19.7	1.09	0.732
18	11/16	21.1	23.0	24.9	1.37	0.921
19	3/4	23.5	25.6	27.7	1.53	1.03
20	13/16	26.0	28.4	30.8	1.70	1.14
22	7/8	31.5	34.4	37.2	2.05	1.38
24	15/16	37.5	40.9	44.3	2.44	1.64
26	1	43.3	47.3	51.2	2.82	1.90
28	1+1/8	51.8	56.5	61.2	3.37	2.26
30	—	58.6	63.9	69.3	3.82	2.57
32	1+1/4	66.7	72.7	78.8	4.34	2.92
34	—	75.3	82.1	89.0	4.90	3.29
35	1+3/8	79.8	87.0	94.3	5.19	3.49
36	—	84.4	92.1	99.8	5.50	3.70
38	1+1/2	94.0	102	111	6.13	4.12
40	—	104	113	123	6.79	4.56

Compact Wire Rope 6 x 31(WS)C+IWRC, 6 x 36(WS)C+IWRC, 6 x 41(WS)C+IWRC						
Dia.of Wire Rope (mm)	Dia.of Wire Rope (in.)	Breaking Load(ton)			Approx. Weight (kg/m)	Approx. Weight (Lb/ft)
		Grade A	Grade B	Grade C		
10	—	7.1	7.8	8.5	0.466	0.313
11	7/16	8.7	9.5	10.3	0.564	0.379
12	—	10.2	11.2	12.1	0.672	0.452
13	1/2	12.0	13.2	14.2	0.789	0.530
14	9/16	14.2	15.5	16.8	0.913	0.614
16	5/8	18.3	19.9	21.7	1.19	0.801
18	11/16	23.2	25.3	27.4	1.51	1.02
19	3/4	25.9	28.2	30.5	1.68	1.13
20	13/16	28.6	31.2	33.9	1.86	1.25
22	7/8	34.7	37.8	40.9	2.25	1.51
24	15/16	41.3	45.0	48.7	2.68	1.80
26	1	47.6	52.0	56.3	3.14	2.11
28	1+1/8	57.0	62.2	67.3	3.64	2.45
30	—	64.5	70.3	76.2	4.19	2.82
32	1+1/4	73.4	80.0	86.7	4.76	3.20
34	—	82.8	90.3	97.9	5.37	3.61
35	1+3/8	87.8	95.7	103	5.71	3.84
36	—	92.8	101	110	6.03	4.05
38	1+1/2	103	112	122	6.71	4.51
40	—	114	124	135	7.47	5.02



COMPACT WIRE ROPE

Compact Wire Rope 19 x 7				
Dia.of Wire Rope (mm)	Breaking Load(ton)			Approx. Weight (kg/m)
	Bright or Drawn galv.		Bright	
	Grade A	Grade B		
9.00	5.88	6.42	6.95	0.390
9.50	6.56	7.15	7.75	0.434
10.0	7.26	7.92	8.58	0.481
11.2	9.11	9.94	10.8	0.604
12.0	10.5	11.4	12.4	0.693
12.6	11.5	12.6	13.6	0.764
13.0	12.3	13.4	14.5	0.813
14.0	14.2	15.5	16.8	0.943
14.3	14.9	16.2	17.6	0.984
15.0	16.3	17.8	19.3	1.083
16.0	18.6	20.3	22.0	1.232
17.5	22.2	24.3	26.3	1.474
18.0	23.5	25.7	27.8	1.559
19.0	26.2	28.6	31.0	1.737
20.0	29.1	31.7	34.3	1.925
21.0	32.0	34.9	37.9	2.122
22.4	36.4	39.8	43.1	2.415
24.0	41.8	45.6	49.4	2.772
25.0	45.4	49.5	53.7	3.008
25.4	46.9	51.1	55.4	3.105
28.0	56.9	62.1	67.3	3.773
30.0	65.4	71.3	77.3	4.331
32.0	74.4	81.1	87.9	4.928
34.0	84.0	91.6	99.2	5.563
35.0	89.0	97.1	105	5.895
36.0	94.1	103	111	6.237
38.0	105	114	124	6.949

Compact Wire Rope 35 x 7					
Dia.of Wire Rope (mm)	Breaking Load(ton)				Approx. Weight (kg/m)
	Galvanized	Bright or Drawn galv.		Bright	
		Grade G	Grade A		
16.0	17.8	19.6	21.4	23.1	1.32
17.5	21.3	23.4	25.6	27.7	1.58
18.0	22.5	24.8	27.0	29.3	1.67
19.0	25.1	27.6	30.1	32.6	1.86
20.0	27.8	30.6	33.4	36.2	2.06
21.0	30.7	33.7	36.8	39.9	2.28
22.4	34.9	38.4	41.9	45.4	2.59
24.0	40.1	44.1	48.1	52.1	2.97
25.0	43.5	47.8	52.2	56.5	3.22
25.4	44.9	49.4	53.8	58.3	3.33
26.0	47.0	51.7	56.4	61.1	3.49
28.0	54.5	60.0	65.4	70.9	4.04
28.6	56.9	62.6	68.3	73.9	4.22
30.0	62.6	68.8	75.1	81.4	4.64
32.0	71.2	78.3	85.5	92.6	5.28
34.0	80.4	88.4	96.5	105	5.96
35.0	85.2	93.7	102	111	6.32
36.0	90.1	99.1	108	117	6.69
38.0	100	110	121	131	7.45



YG-5 WIRE ROPE

YG-5 means YoungHeung + Galvanization
It is ultra highest corrosion resistance galvanized wire
in producing with accumulated
Young Heung's advanced technology.

Environments of usage

YG-5 is over 2 times longer resistance for red rust comparing to zinc galvanized wire.
The superiority of corrosion resistance is enable to specially perform without any limit of environments.
Especially, YG-5 is suitable for corrosive environment such as seashore ocean working site.

Youngwire's Products

YG-5 is applicable to all kinds of Steel Wire products such as Agricultural Wires, Automotive Cable, Wire Rope for fishing industry etc.
We make sure this higher new invented item will be obviously make out our customer's successful business.

Corrosion resistance

YG-5 has over 2 times longer resistance to corrosion than normal Hot Dipped Zinc Coating

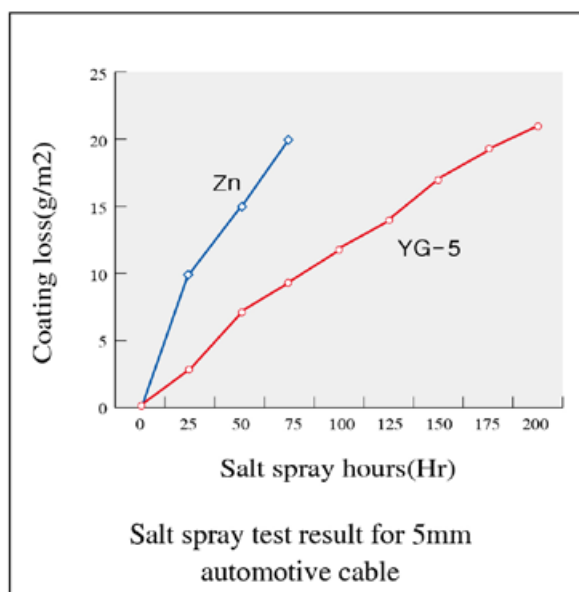
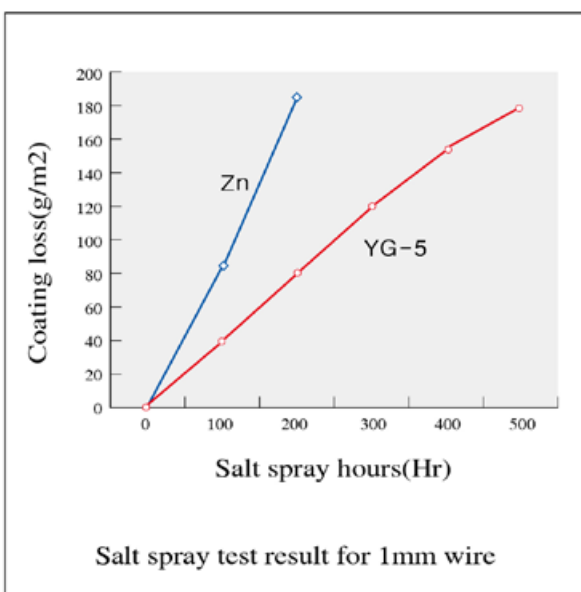

Salt spray test : ASTM B 117



YG-5 WIRE ROPE



The rust occurrence for 1mm zinc galvanized wire after 200hours



The rust occurrence for 1mm YG-5 wire after 500hours

Mechanical properties

The mechanical properties of YG-5 wire is similar to those of Zinc Galvanized Wire.

Mechanical properties of 1mm Galvanized Patented Wire

	Normal Zn coating	YG-5
T/S(Kg/mm ²)	108	112
T/O(100D)	20	19

Homogeneous coating film

YG-5 has a more homogeneous and ductile coating compared to Zinc Coating.

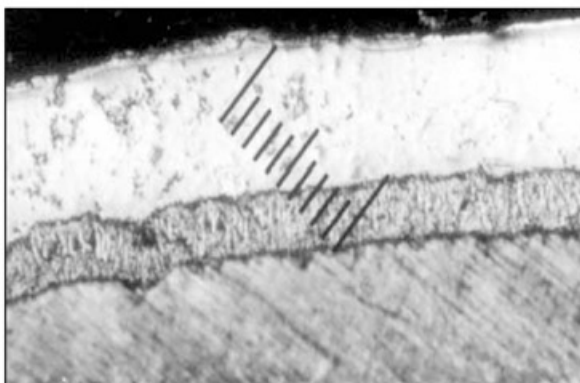

Microstructure of zinc hot-dip galvanized wire

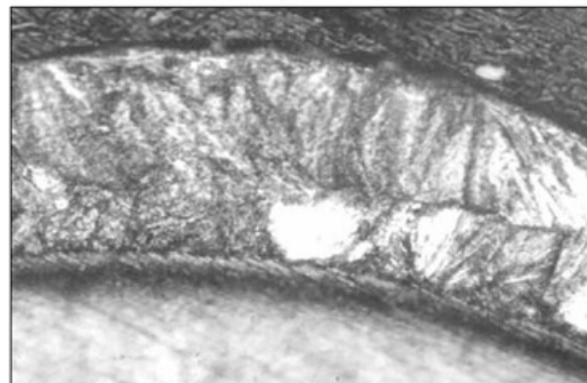

Microstructure of YG-5 galvanized wire

Hardness

YG-5 has a two times harder than Zinc Coating Wire, it has surely better character for abrasion resistance & scratch.



YG-5 WIRE ROPE

After-draw ability

After YG-5 coating, after-draw ability is similar to those of Zinc Coating Wire.

Surface appearance

The surface of YG-5 is appeared dark gray, no luster. Accordingly, it doesn't have the diffused reflection.

Production range

1. WIRE ROPE

Construction	Range of product	Construction	Range of product
6x7	6.0mm - 26.0mm	6x19	10.0mm - 40.0mm
6x24	12.0mm - 40.0mm	6x37	10.0mm - 40.0mm
6x19(s)	8.0mm - 32.0mm	6x25(Fi)	8.0mm - 40.0mm
6x26(ws)	8.0mm - 32.0mm	6x36(ws)	8.0mm - 40.0mm
8x19(s)	10.0mm - 40.0mm	8x36(ws)	10.0mm - 40.0mm

2. CONTROL CABLE

TYPE	Range of product	Construction
Strand Type	1.0mm - 5.0mm	1x7, 3+9, 1x19
Rope Type	1.0mm - 5.0mm	7x7, 8x7+1x19, 7x19

Main application

YG-5 is applicable to many various industry
YG-5 of high corrosion resistance has
conspicuous character to resist rust from sea water.

Automotive cable
Wire rope for fishing industry
Wire rope for shipping industry
Guard cable
Protection wire for a rockslide
Farm industry



PLASTIC IMPREGNATED WIRE ROPE

SEMI-IP ROPE

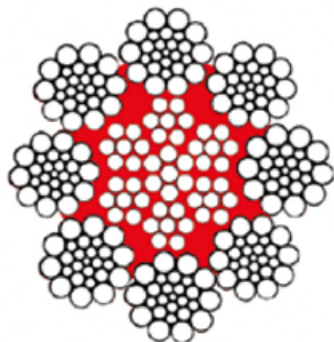

YoungHeung's SEMI - IP ROPE with plastic impregnated IWRC

Our Semi-IP Rope serves much longer service life. Plastic are filled between outer strands and inner IWRC to reduce the friction of each wire. The fatigue resistance is increased with our Semi - IP rope due to the fact that it is more stable than general rope in structure.

CHARACTERISTICS

Increases Service Life

The process of YoungHeung's Semi-IP core enhancement minimizes internal core damages and prevents internal wire breaks.

Excellent Construction Stability

With a plastics filling system, the core movements are suppressed. The core not receive more abuse than the out strands.

Cushion between the layers

The plastics filling system acts as a cushion in between strands and core. It has a good abrasion resistance and prevents metal-to-metal contact.

Keeps Out Water

Keeps out water and prevents internal corrosion

Available in right and left hand lay

Lower Equipment Maintenance Costs & Minimizes Downtime



ELEVATOR WIRE ROPE

Our Elevator rope is manufactured with accumulated know-how including wire quality, core, grease, elongation with strict quality control.

We are manufacturing products of uniform quality and removing structural elongation that can easily occur during manufacturing process by performing pretension at the latest equipment.

characteristics :

With superiority on good service life, low elongation, no excessive sheave wear, uniform diameter

- ▶ Use of special grease to improve anti-corrosion and anti-abrasion
- ▶ Through pretension process, by eliminating the gaps between strands, each strand has equal tension and rope diameter becomes uniform. easy to handle and set up by getting rid of character of rotation.

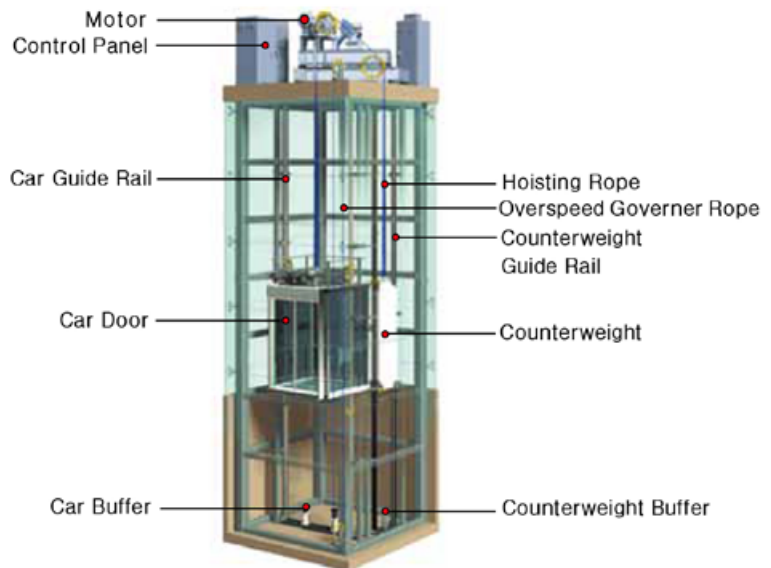

Rope Diameter

Dia.of Wire Rope (mm)	Permissible tolerance			
	Fibre cored		Steel cored	
	No load	10% of Fmin	No load	10% of Fmin
up to 10	max. 6%	min. 0%	max. 3%	min. -1%
greater than to 10	max. 5%	min. 0%	max. 2%	min. -1%

Maintenance

The rope should be replaced if the rope diameter is reduced by more than 6 percent based on a rope nominal diameter.



ELEVATOR WIRE ROPE

8 x 19(S)+FC, 8 x 19(W)+FC, 8 x 25(FI)+FC											
Dia.of Wire Rope		Breaking Load							Approx.Weight		
		EN 12385(KN)		FS(RR-W-410)(Lb)		JIS G 3525 (KN)			EN (kg/m)	FS (Lb/ft)	JIS (kg/m)
(mm)	(in.)	Grade 1370/1770	Grade 1570	Traction Steel	Extra High Traction	Grade E	Grade A	Grade B			
8	5/16	28.1	29.4	5,600	6,900	26.0	30.8	32.8	0.218	0.14	0.220
9	3/8	35.6	37.3	8,200	9,900	32.9	39.0	41.5	0.275	0.20	0.278
10		44.0	46.0			40.6	48.1	51.3	0.340		0.343
11	7/16	53.2	55.7	11,000	13,500	51.0	60.3	64.3	0.411	0.28	0.430
12	1/2	63.3	66.2	14,500	17,500	58.5	69.2	73.8	0.490	0.36	0.494
13		74.3	77.7			68.7	81.2	86.6	0.575		0.579
14	9/16	86.1	90.2	18,500	22,100	79.6	94.3	100	0.666	0.46	0.672
16	5/8	113	118	23,000	27,200	104	123	131	0.870	0.57	0.878
18	3/4	142	149	32,000	38,900	132	156	166	1.10	0.82	1.11
19		159	166			147	174	185	1.23		1.24
20	13/16	176	184	37,000	46,000	162	192	205	1.36	0.96	1.37

8 x 19(S)+IWRC, 8 x 19(W)+IWRC, 8 x 25(FI)+IWRC					
Dia.of Wire Rope (mm)	EN 12385 Breaking Load(KN)				Approx. Weight (kg/m)
	Grade 1370/1770	Grade 1570/1770	Grade 1570	Grade 1770	
8	35.8	38.0	35.8	40.3	0.260
9	45.3	48.2	45.3	51.0	0.330
10	55.9	59.5	55.9	63.0	0.407
11	67.6	71.9	67.6	76.2	0.492
12	80.5	85.6	80.5	90.7	0.586
13	94.5	100	94.5	106	0.687
14	110	117	110	124	0.798
16	143	152	143	161	1.04
18	181	193	181	204	1.32
19	202	215	202	227	1.47
20	224	238	224	252	1.63

6 x 19(S)+FC, 6 x 19(W)+FC, 6 x 25(FI)+FC												
Dia.of Wire Rope		Breaking Load							Approx.Weight			
		EN 12385(KN)			FS(RR-W-410)(Lb)		JIS G 3525 (KN)			EN (kg/m)	FS (Lb/ft)	JIS (kg/m)
(mm)	(in.)	Grade 1370/1770	Grade 1570	Grade 1770	Traction Steel	Extra High Traction	Grade E	Grade A	Grade B			
8	5/16	31.7	33.2	37.4	5,600	8,200	28.6	34.9	37.2	0.230	0.16	0.247
9	3/8	40.1	42.0	47.3	8,200	11,600	36.2	44.1	47.0	0.291	0.23	0.312
10		49.5	51.8	58.4			44.7	54.5	58.1	0.359		0.386
11	7/16	59.5	62.7	70.7	11,000	15,800	56.1	68.3	72.8	0.434	0.31	0.484
12	1/2	71.3	74.6	84.1	14,500	20,400	64.4	78.4	83.6	0.517	0.40	0.556
13		83.7	87.6	98.7			75.6	92.0	98.1	0.607		0.652
14	9/16	97	102	114	18,500	25,800	87.7	107	114	0.704	0.51	0.756
16	5/8	127	133	150	23,000	31,600	115	139	149	0.919	0.63	0.988
18	3/4	160	168	189	32,000	45,200	145	176	188	1.16	0.90	1.25
19		179	187	211			162	196	209	1.30		1.39
20	13/16	198	207	234	37,000	53,000	179	218	232	1.44	1.06	1.54



CABLE LAID ROPE

7 X 7 X 7				
Dia. of Wire Rope (in.)	Breaking Load (Lb)			Approx. Weight (Lb/ft)
	Grade A	Grade B	Grade C	
5/16	6,490	7,080	7,670	0.135
3/8	9,350	10,200	11,100	0.195
7/16	12,900	14,100	15,200	0.273
1/2	16,400	17,900	19,400	0.346
9/16	21,100	23,000	24,900	0.446
5/8	26,500	28,900	31,300	0.558
3/4	37,300	40,700	44,100	0.786
7/8	51,800	56,500	61,200	1.093
1	66,600	72,600	78,700	1.405
1-1/8	84,200	91,900	99,500	1.781
1-1/4	105,600	115,200	124,800	2.230
1-5/16	119,000	129,800	140,600	2.517
1-3/8	126,300	137,800	149,300	2.668
1-7/16	133,600	145,700	157,900	2.822
1-1/2	148,800	162,300	175,900	3.145
1-9/16	164,900	179,900	194,900	3.484

7 X 7 X 19				
Dia. of Wire Rope (in.)	Breaking Load (Lb)			Approx. Weight (Lb/ft)
	Grade A	Grade B	Grade C	
3/8	9,100	9,900	10,800	0.195
7/16	12,700	13,900	15,000	0.270
1/2	16,100	17,600	19,100	0.341
9/16	20,700	22,600	24,500	0.440
5/8	26,000	28,400	30,700	0.550
3/4	36,600	39,900	43,300	0.776
7/8	50,700	55,300	59,900	1.079
1	65,300	71,200	77,200	1.387
1-1/8	82,900	90,400	98,000	1.759
1-1/4	103,600	113,000	122,400	2.202
1-5/16	117,100	127,700	138,400	2.486
1-3/8	124,100	135,400	146,700	2.643
1-7/16	131,200	143,100	155,100	2.787
1-1/2	146,200	159,500	172,800	3.105
1-9/16	162,000	176,700	191,500	3.440

GALVANIZED STEEL WIRE STRAND



PHYSICAL PROPERTIES A.S.T.M. A475

Nominal Diameter of the Strand (in.)	Number of Wires in Strand	Nominal Diameter of Coated Wires in Strand (in.)	Approximate Weight of strand per 1000ft (Lb)	Minimum Breaking Load of Strand(Lb)				
				Utilities Grade	Common Grade	Siemens Martin Grade	High Strength Grade	Extra High Strength Grade
3/16	7	0.062	73		1,150	1,900	2,850	3,990
3/16	7	0.065	80	2,400(1)				
7/32	7	0.072	98		1,540	2,560	3,850	5,400
1/4	3	0.120	117	3,150(2)				
1/4	3	0.120	117	4,500(3)				
1/4	7	0.080	121		1,900	3,150	4,750	6,650
9/32	7	0.093	164	4,600(1)	2,570	4,250	6,400	8,950
5/16	3	0.145	171	6,500(3)				
5/16	7	0.104	205		3,200	5,350	8,000	11,200
5/16	7	0.109	225	6,000(1)				
3/8	3	0.165	220	8,500(3)				
3/8	7	0.120	273	11,500(4)	4,250	6,950	10,800	15,400
7/16	7	0.145	399	18,000(4)	5,700	9,350	14,500	20,800
1/2	7	0.165	517	25,000(4)	7,400	12,100	18,800	26,900

JIS G 3537

Nominal Diameter of the Strand (in.)	No. of Wires. In Strand/ Dia. of Standard Wires (mm)	Nominal Cross Section Area (mm ²)	Minimum Breaking Load of Strand(kN)			Approx. Weight (kg/m)
			Grade 1	Grade 2	Grade 3	
3.0	7/1.00	5.50	6.19	4.48	3.47	0.0435
3.6	7/1.20	7.92	8.90	6.44	4.99	0.0627
4.2	7/1.40	10.8	12.2	8.78	6.83	0.0853
4.8	7/1.60	14.1	15.9	11.5	8.90	0.111
5.4	7/1.80	17.1	20.1	14.4	11.3	0.141
6.0	7/2.00	22.0	24.8	17.8	13.9	0.174
6.9	7/2.30	29.1	32.8	23.6	18.3	0.230
7.8	7/2.60	37.2	42.0	30.2	23.5	0.294
8.7	7/2.90	46.2	52.2	37.6	29.2	0.366
9.6	7/3.20	56.3	63.7	45.7	35.6	0.446
10.5	7/3.50	67.3	75.8	54.7	42.5	0.533
11.4	7/3.80	79.3	89.8	64.4	50.1	0.628
12.0	7/4.00	88.0	99.1	71.4	55.6	0.696
12.9	7/4.30	102	115	82.8	64.4	0.805

JIS G 3521 HARD DRAWN STEEL WIRE



Diameter of Wire (mm)	Tensile Strength(N/mm ²)		
	SW-A	SW-B	SW-C
0.08	2110~2450	2450~2790	2790~3140
0.09	2060~2400	2400~2750	2750~3090
0.10	2010~2350	2350~2700	2700~3040
0.12	1960~2300	2300~2650	2650~2990
0.14	1960~2260	2260~2600	2600~2940
0.16	1910~2210	2210~2550	2550~2890
0.18	1910~2210	2210~2500	2500~2840
0.20	1910~2210	2210~2500	2500~2790
0.23	1860~2160	2160~2450	2450~2750
0.26	1810~2110	2110~2400	2400~2700
0.29	1770~2060	2060~2350	2350~2650
0.32	1720~2010	2010~2300	2300~2600
0.35	1720~2010	2010~2300	2300~2600
0.40	1670~1960	1960~2260	2260~2550
0.45	1620~1910	1910~2210	2210~2500
0.50	1620~1910	1910~2210	2210~2500
0.55	1570~1860	1860~2160	2160~2450
0.60	1570~1810	1810~2110	2110~2400
0.65	1570~1810	1810~2110	2110~2400
0.70	1520~1770	1770~2060	2060~2350
0.80	1520~1770	1770~2010	2010~2300
0.90	1520~1770	1770~2010	2010~2260
1.00	1470~1720	1720~1960	1960~2210
1.20	1420~1670	1670~1910	1910~2160
1.40	1370~1620	1620~1860	1860~2110
1.60	1320~1570	1570~1810	1810~2060
1.80	1270~1520	1520~1770	1770~2010
2.00	1270~1470	1470~1720	1720~1960
2.30	1230~1420	1420~1670	1670~1910
2.60	1230~1420	1420~1670	1670~1910
2.90	1180~1370	1370~1620	1620~1860
3.20	1180~1370	1370~1570	1570~1810
3.50	1180~1370	1370~1570	1570~1770
4.00	1180~1370	1370~1570	1570~1770
4.50	1130~1320	1320~1520	1520~1720
5.00	1130~1320	1320~1520	1520~1720
5.50	1080~1270	1270~1470	1470~1670
6.00	1030~1230	1230~1420	1420~1620
6.50	1030~1230	1230~1420	1420~1620
7.00	980~1180	1180~1370	1370~1570
8.00	980~1180	1180~1370	1370~1570
9.00	930~1130	1130~1320	1320~1520
10.00	930~1130	1130~1320	1320~1520
11.00	—	1080~1270	1270~1470
12.00	—	1080~1270	1270~1470
13.00	—	1030~1230	1230~1420

Remark : For the wire whose diameter is an intermediate between those given in the above table, the value specified for the nearest larger diameter shall applied.

ASTM, BS, DIN AND BUYER'S SPECIFICATION ARE ALSO AVAILABLE



JIS G 3522 PIANO WIRE

Diameter of Wire (mm)	Tensile Strength(N/mm ²)		
	SWP-A	SWP-B	SWP-V
0.08	2890~3190	3190~3480	-
0.09	2840~3140	3140~3430	-
0.10	2790~3090	3090~3380	-
0.12	2750~3040	3040~3330	-
0.14	2700~2990	2990~3290	-
0.16	2650~2940	2940~3240	-
0.18	2600~2890	2890~3190	-
0.20	2600~2840	2840~3090	-
0.23	2550~2790	2790~3040	-
0.26	2500~2750	2750~2990	-
0.29	2450~2700	2700~2940	-
0.32	2400~2650	2650~2890	-
0.35	2400~2650	2650~2890	-
0.40	2350~2600	2600~2840	-
0.45	2300~2550	2550~2790	-
0.50	2300~2550	2550~2790	-
0.55	2260~2500	2500~2750	-
0.60	2210~2450	2450~2700	-
0.65	2210~2450	2450~2700	-
0.70	2160~2400	2400~2650	-
0.80	2110~2350	2350~2600	-
0.90	2110~2300	2300~2500	-
1.00	2060~2260	2260~2450	2010~2210
1.20	2010~2210	2210~2400	1960~2160
1.40	1960~2160	2160~2350	1910~2110
1.60	1910~2110	2110~2300	1860~2060
1.80	1860~2060	2060~2260	1810~2010
2.00	1810~2010	2010~2210	1770~1910
2.30	1770~1960	1960~2160	1720~1860
2.60	1770~1960	1960~2160	1720~1860
2.90	1720~1910	1910~2110	1720~1860
3.20	1670~1860	1860~2060	1670~1810
3.50	1670~1810	1810~1960	1670~1810
4.00	1670~1810	1810~1960	1670~1810
4.50	1620~1770	1770~1910	1620~1770
5.00	1620~1770	1770~1910	1620~1770
5.50	1570~1710	1710~1860	1570~1720
6.00	1520~1670	1670~1810	1520~1670
6.50	1520~1670	1670~1810	-
7.00	1470~1620	1620~1770	-
8.00	1470~1620	-	-
9.00	1420~1570	-	-
10.00	1420~1570	-	-

Remark : For the wire whose diameter is an intermediate between those given in the above table, the value specified for the nearest larger diameter shall applied.
 ASTM, BS, DIN AND BUYER'S SPECIFICATION ARE ALSO AVAILABLE

STANDARD LUBRICATION CHART FOR WIRE ROPE



LUBE TYPE	LUBE MATERIAL	APPLICATION	APPEARANCE	USE FOR GENERAL PURPOSE
DRY-S	RUST PREVENT OIL (LIGHT OIL)	VERY LIGHT APPLICATION VERY TIGHTLY WIPED	NON DRY TYPE FILM AND BRIGHT, COMPLETELY NO GREASE AND NON TACKY	GALV A/C, INNER CABLE GALV STEEL WIRE, HARD DRAWN STEEL WIRE, GALV WIRE ROPE ETC.
DRY	DITTO	DITTO	DRY TYPE FILM & BRIGHT, COMPLETELY NO GREASE AND NON TACKY	GALV A/C, INNER CABLE GALV STEEL WIRE ROPE ETC.
A-1	PETROLATUM BASE GREASE	VERY LIGHT DUTY. TIGHTLY WIPED	VERY LIGHT GREASE	GALV/UNGALV WIRE ROPES
A-2	DITTO	LIGHT DUTY, LOOSELY WIPED	LIGHT GREASE	DITTO
A-3	DITTO	NOT WIPED DOUBLE GREASED INSIDE & OUTSIDE	HEAVY GREASE	DITTO
B	PETROLATUM 60% ASPHALTUM 40% MIXED GREASE	MEDIUM DUTY, TIGHTLY WIPED	DARK GREASE SLIGHTLY WET	DITTO
C	ASPHALTUM BASE GREASE	HEAVY DUTY, LOOSELY WIPED	BLACK GREASE AND WET APPEARANCE	DITTO
D	DITTO	VERY HEAVY DUTY, NOT WIPED, DOUBLE GREASED INSIDE & OUTSIDE	VERY BLACK, WET AND TACKY	DITTO



HOW TO ORDER STEEL WIRE ROPE

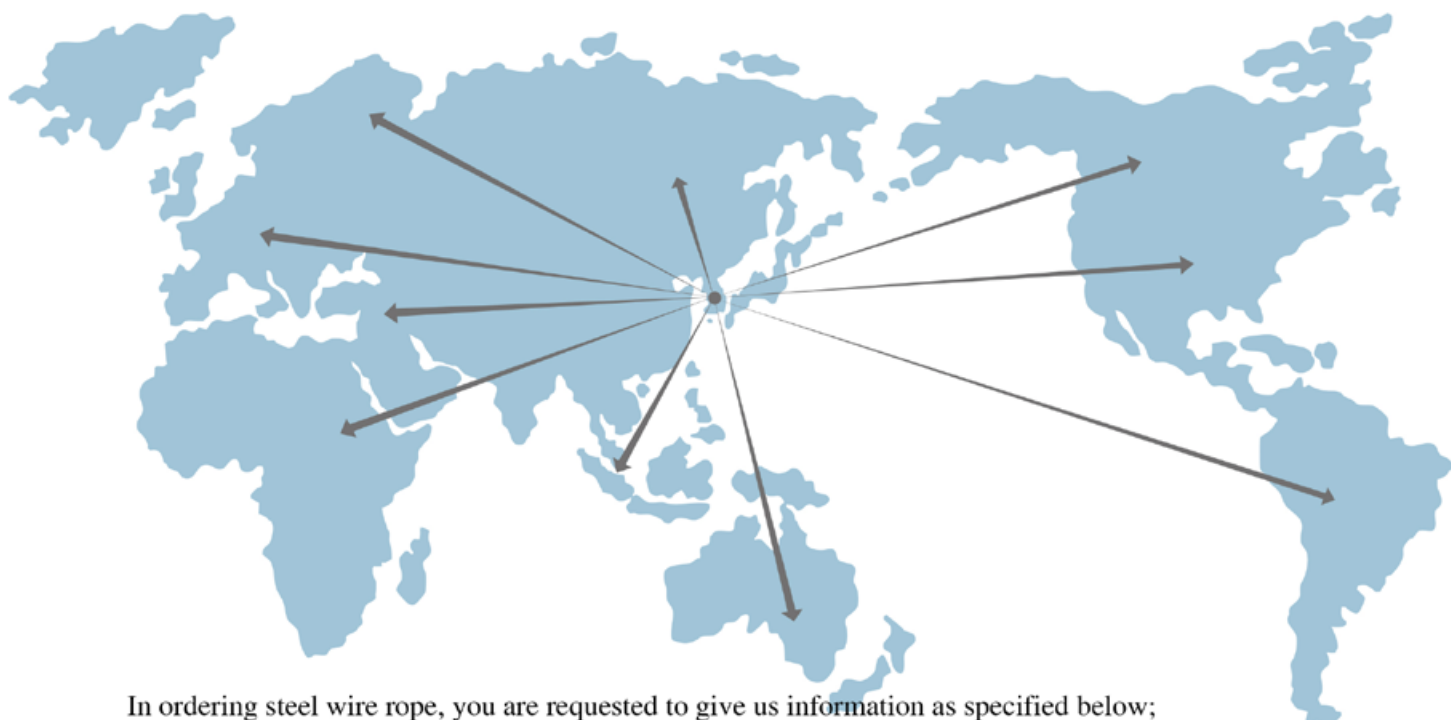

In ordering steel wire rope, you are requested to give us information as specified below;

- | | |
|--------------------------|---|
| 1. PURPOSE | : For which the rope will be used. |
| 2. SIZE | : Diameter of the rope in millimeters or inches |
| 3. CONSTRUCTION | : Number of strands, number of wires per strand, and type of strand construction. |
| 4. TYPE OF CORE | : Fiber Core(FC), Independent Wire Rope Core(IWRC) or Independent Wire Strand Core(IWSC). |
| 5. LAY | : Right Regular Lay, Left Regular Lay, Right Lang Lay, or Left Lang Lay. |
| 6. FABRICATION | : Preformed or not. |
| 7. COATING | : Bright(Black, Ungalvanized)or Galvanized. |
| 8. GRADE OF WIRES | : Tensile Strength of Wires |
| 9. BREAKING LOAD | : Minimum or Calculated Breaking Load in tons or pounds. |
| 10. LUBRICATION | : Whether lubricant is desired or not.
Any required Lubricant. |
| 11. LENGTH | : Length of Wire Rope |
| 12. PACKING | : In coils wrapped with oil paper and hessian(or P.P.)cloth, or on wooden reels. |
| 13. QUANTITY | : By number of coils or reels, by length or weight. |
| 14. SPECIFICATION | : Any recognized specification, if necessary. |
| 15. CERTIFICATE | : Mill Sheet and/or a third party's inspection, if needed. |
| 16. REMARKS | : Shipping Marks and any other special requirements. |

INNER CABLE



GAC & INNER CABLE

INNER CABLE

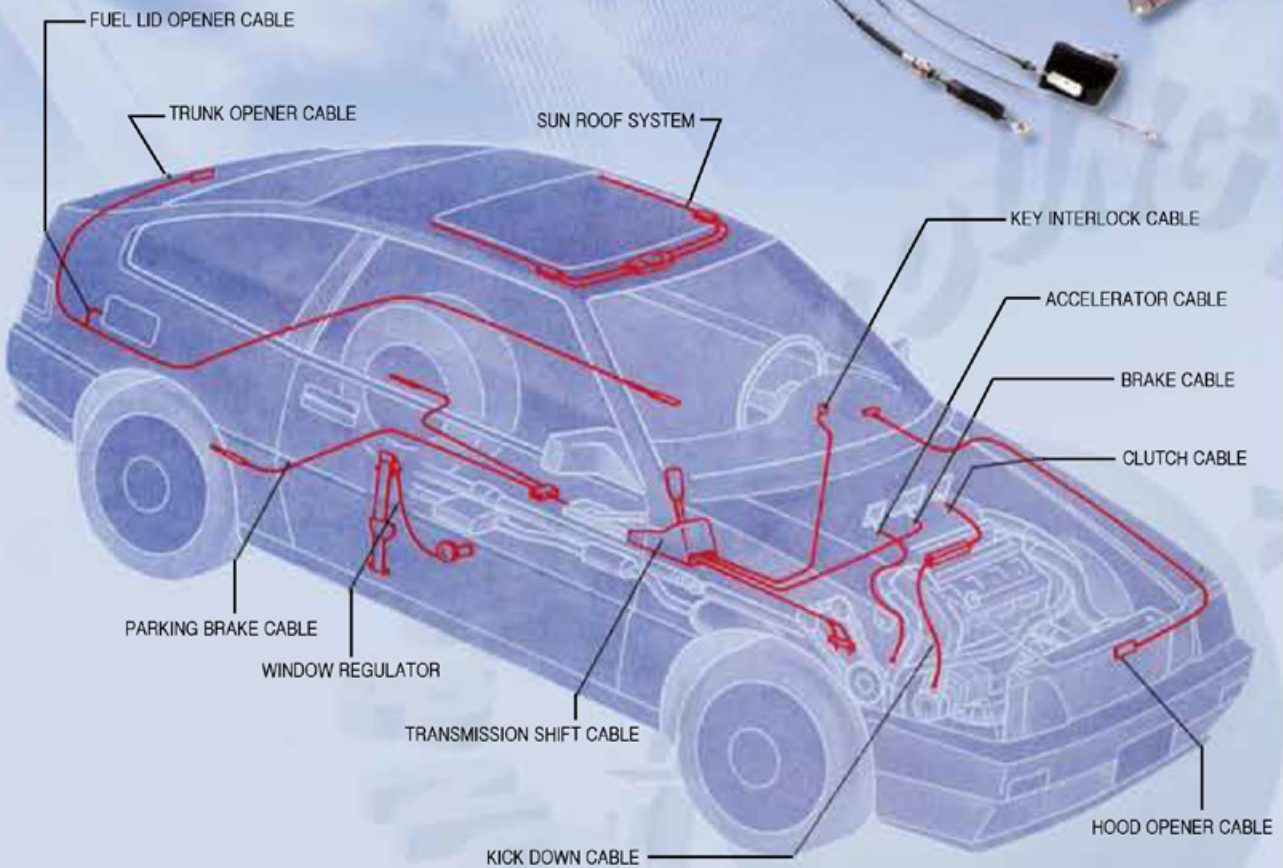

GALVANIZED AIRCRAFT CABLE



Diameter		7 x 7			7 x 19			1 x 19	
		GAC	SSA/C	GAC & SSA/C	GAC	SSA/C	GAC & SSA/C	GAC & SSA/C	GAC & SSA/C
(mm)	(in.)	MinBreaking Load (kg)	MinBreaking Load (kg)	Weight (kg/100m)	Min Breaking Load (kg)	Min Breaking Load (kg)	Weight (kg/100m)	Min Breaking Load (kg)	Weight (kg/100m)
0.79	1/32	-	-	-	-	-	-	84	0.32
1.19	3/64	-	-	-	-	-	-	170	0.82
1.59	1/16	218	218	1.12	-	-	-	227	1.26
1.98	5/64	295	295	1.64	-	-	-	363	2.08
2.38	3/32	417	417	2.38	454	417	2.59	544	2.98
2.78	7/64	572	572	3.27	635	572	3.27	726	4.02
3.18	1/8	771	771	4.17	907	798	4.32	953	5.21
3.57	9/64	953	953	5.27	1043	953	5.42	1279	6.07
3.97	5/32	1179	1089	6.40	1270	1089	6.70	1497	8.19
4.76	3/16	1678	1678	9.23	1905	1678	9.67	2132	11.50
5.56	7/32	2177	2177	12.34	2540	2268	12.80	2858	15.20
6.35	1/4	2767	2767	15.76	3175	2903	16.40	3720	20.10
7.14	9/32	3447	3447	19.93	3629	3538	20.70	4672	25.30
7.94	5/16	4173	4082	24.84	4445	4082	25.70	5670	31.30
9.53	3/8	5942	5443	35.10	6532	5443	36.20	7938	44.80

P.V.C COATED CABLE

Construction	Diameter (mm)		Min Breaking Load	Weight					
	Inside Dia.	Outside Dia.		CABLE		P.C.V		Total Weight	
			kg	LP/100ft	kg/100m	Lb/100ft	kg/100m	Lb/100ft	kg/100m
7 x 7	1.59	2.38	218	0.75	1.12	0.23	0.34	0.98	1.46
	1.59	3.18	218	0.75	1.12	0.51	0.76	1.26	1.88
	1.59	4.76	218	0.75	1.12	1.31	1.95	2.06	3.07
	2.38	3.18	417	1.60	2.38	0.35	0.52	1.95	2.90
	2.38	3.97	417	1.60	2.38	0.71	1.06	2.31	3.44
	2.38	4.76	417	1.60	2.38	1.15	1.71	2.75	4.09
	3.18	4.76	771	2.80	4.17	0.92	1.37	3.72	5.54
	3.18	6.35	771	2.80	4.17	2.04	3.04	4.84	7.21
7 x 19	4.76	7.94	1678	6.20	9.23	2.87	4.27	9.07	13.5
	3.18	4.76	907	2.90	4.32	0.92	1.37	3.82	5.69
	3.18	5.56	907	2.90	4.32	1.45	2.15	4.35	6.47
	3.18	6.35	907	2.90	4.32	2.05	3.04	4.95	7.36
	3.97	5.56	1270	4.50	6.70	1.16	1.72	5.66	8.42
	4.76	6.35	1905	6.50	9.67	1.43	2.13	7.93	11.8
	4.76	7.94	1905	6.50	9.67	2.84	4.23	9.43	13.9
	6.35	7.94	3175	11.02	16.4	1.98	2.90	13.0	19.3
	6.35	9.53	3175	11.02	16.4	3.98	5.50	15.0	21.90
	7.94	10.32	4445	17.3	25.7	3.82	5.28	21.12	30.98
	7.94	11.1	4445	17.3	25.7	4.96	6.85	22.26	32.55
9.53	11.1	6532	24.3	36.2	3.44	4.76	27.74	40.96	
9.53	11.9	6532	24.3	36.2	4.70	6.49	29.0	42.69	



INNER CABLE

Construction	Diameter(mm)	Min. Breaking Load (kg)	Weight (kg/1000m)
1 x 3	0.20	4.5	0.19
	0.24	6.5	0.27
	0.30	10	0.42
	0.34	13	0.54
	0.40	18	0.76
	0.52	28	1.27
1 x 7	0.30	10	0.44
	0.36	15	0.64
	0.40	18	0.75
	0.45	23	1.0
	0.50	30	1.25
	0.60	41	1.8
	0.75	60	2.8
	0.80	78	3.14
	0.90	90	4.0
1 x 12	1.0	110	4.8
	1.2	150	7.0
	1.5	230	11.6
1 x 12	1.0	105	4.9
	1.2	145	6.9
	1.5	230	10.8
1 x 13	1.2	136	7.9
	1.6	242	13.9
	2.3	590	27.2
	3.2	719	51.3
1 x 19	3.4	812	62.4
	0.5	29	1.25
	0.6	40	1.79
	0.7	55	2.44
	0.8	72	3.20
	0.9	90	4.03
	1.0	110	4.98
	1.2	150	8.20
	1.5	250	11.6
	1.6	280	12.8
	1.8	340	16.0
	2.0	430	21.2
	2.38	560	29.8
2.5	640	32.9	
3.0	850	46.9	
3.5	1100	61.8	
4.0	1500	83.2	
1 x 27	1.2	160	7.0
	1.5	230	11.0
	2.0	400	19.2
	2.5	640	30.0
	3.0	850	43.2
3.5	1100	58.8	

Construction	Diameter(mm)	Min. Breaking Load (kg)	Weight (kg/1000m)
1 x 37	4.0	1600	76.4
	4.8	1790	112.0
3 x 7	0.60	30	1.36
	0.79	50	2.38
	0.90	65	3.07
	1.0	83	3.9
	1.2	110	5.45
	1.3	130	6.58
7 x 7	1.5	170	8.5
	0.90	69	3.26
	1.0	82	3.93
	1.2	120	6.25
	1.5	180	9.9
	1.59	218	11.2
	2.0	310	16.7
	2.38	417	23.8
	2.5	480	26.5
	3.0	700	37.7
	3.1	740	40.2
	3.2	776	42.0
	3.5	900	50.8
	4.0	1150	65.1
	5.0	1700	102
6.0	2300	143	
7 x 19	1.5	180	9.93
	1.59	200	11.16
	1.8	256	14.8
	2.0	300	18.3
	2.38	430	25.9
	2.5	475	27.5
	3.0	700	38.6
	3.18	907	43.2
	3.5	1099	52.9
	4.0	1270	68.2
	4.76	1910	96.7
	5.0	2107	106
	5.56	2540	128
	6.0	2958	148
	6.35	3180	164
8.0	4450	257	
9.0	5632	330	
9.35	6530	362	
8 x 7+ (1 x 19)	1.5	250	10.4
	1.8	360	15.1
	2.0	420	18.7

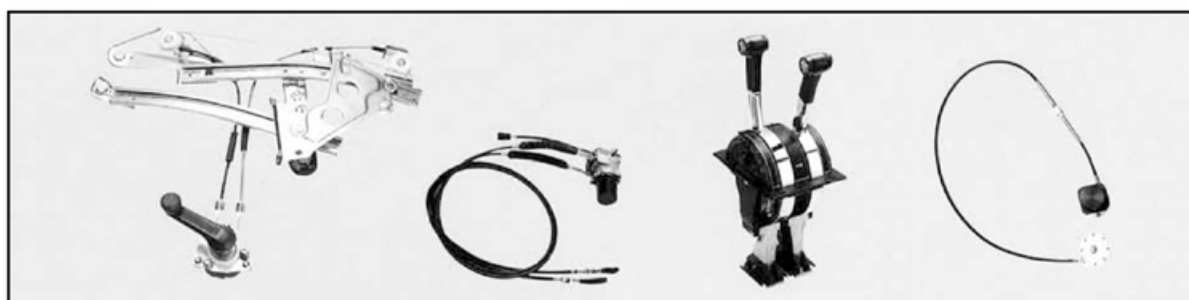

LOW RELAXATION PRESTRESSED CONCRETE



Drawing Process



Stranding Process



Pulling & Heat Treatment Process



Take-up Process



QUALITY CONTROL

Dead Straight

Good preforming of strand

Higher Breaking & Yield Strength

Low Relaxation at elevated temperatures

LOW RELAXATION
PRESTRESSED CONCRETE





USE

PRE-TENSION Pile & Pole, Concrete Slab, Prestressed Concrete Pipe & Tubes Concrete Railway Sleepers,

POST-TENSION Prestressed Concrete Structures, Roofing Structures, Concrete Storage Tank, Concrete Bridges or Viaducts, Concrete Anchor, Atomic Furnace

What is Low Relaxation?

L/R-PC strand is used in order to reinforce the concrete structure.

Any prestressing steel, either wire strand and bar, which are stressed and embedded in concrete lose the applied stress exponential function with time.

Relaxation is indicated percentage which is degree of stress loss as P.C strand is pulled.

This rate is the most important because it is used in the design of prestressed concrete structures.

However, stress loss can be reduced due to relaxation.

An additional advantage can be anticipated when L/R-PC strand is subject to the stabilization by high frequency heating during the tension process.



LOW RELAXATION PRESTRESSED CONCRETE



Standard	Grade	Nominal Dia.		Tolerance of Dia.		Unit/Weight		Breaking Load (Min)		Minimum Load at (0.2%) Extension		Elongation% (Min) in 24 inches	Pitch	Relaxation	
		in.	mm	in.	mm	Lb/1000ft	kg/km	Lb	kg	Lb	kg				
ASTM A 416-80	250	1/4	6.35	±0.016	±0.41	122	182	9,000	4,080	7,650	3,470	3.5	12-16D	Max. 2.5% Per 1000 Hr (B.L * x 0.70)	
		5/16	7.94	±0.016	±0.41	197	294	14,500	6,580	12,300	5,580	3.5	12-16D		
		3/8	9.53	±0.016	±0.41	272	405	20,000	9,070	17,000	7,710	3.5	12-16D		
		7/16	11.11	±0.016	±0.41	367	548	27,000	12,250	23,000	10,430	3.5	12-16D		
		1/2	12.70	±0.016	±0.41	490	730	30,600	16,330	30,600	13,880	3.5	12-16D		
	0.6	15.24	±0.016	±0.41	737	1094	54,000	24,490	45,900	20,820	3.5	12-16D			
	270	3/8	9.53	9.53	+0.026 -0.006	+0.66 -0.15	290	432	23,000	10,430	19,550	8,870	3.5	12-16D	Max. 3.5% Per 1000 Hr (B.L * x 0.80)
		7/16	11.11	11.11	+0.026 -0.006	+0.66 -0.15	390	582	31,000	14,060	26,350	11,950	3.5	12-16D	
		1/2	12.70	12.70	+0.026 -0.006	+0.66 -0.15	520	775	41,300	18,370	35,100	15,920	3.5	12-16D	
		0.6	15.24	15.24	+0.026 -0.006	+0.66 -0.15	740	1102	58,600	26,580	49,800	22,590	3.5	12-16D	
BS 5896-80	STANDARD	3/8	9.3	+0.012 -0.006	+0.3 -0.15	274	408	20,680	9,380	18,120	8,260	3.5	12-16D	Max. 2.5% Per 1000 Hr (B.L * x 0.70)	
		7/16	11.0	+0.012 -0.006	+0.3 -0.15	374	557	28,100	12,740	24,730	11,210	3.5	12-16D		
		1/2	12.5	+0.016 -0.008	+0.4 -0.2	490	730	36,870	16,720	32,370	14,680	3.5	12-16D		
		0.6	15.2	+0.016 -0.008	+0.4 -0.2	732	1090	52,150	23,650	45,860	20,800	3.5	12-16D		
	SUPER	5/16	8.0	8.0	+0.012 -0.006	+0.3 -0.15	200	298	15,730	7,140	13,170	6,220	3.5	12-16D	Max. 4.5% Per 1000 Hr (B.L * x 0.80)
		3/8	9.6	9.6	+0.012 -0.006	+0.3 -0.15	290	432	22,930	10,400	20,230	9,180	3.5	12-16D	
		7/16	11.3	11.3	+0.012 -0.006	+0.3 -0.15	396	590	31,250	14,170	27,420	12,440	3.5	12-16D	
		1/2	12.9	12.9	+0.016 -0.008	+0.4 -0.2	527	785	41,810	18,970	36,640	16,620	3.5	12-16D	
		0.6	15.7	15.7	+0.016 -0.008	+0.4 -0.2	792	1180	59,570	27,020	52,380	23,760	3.5	12-16D	
KS D7002-95 & JIS G3536-84	SWPC 7A (175kg/mm ²)	1/4	6.2	+0.016 -0.008	+0.4 -0.2	122	182	9,040	4,100	7,600	3,450	3.5	12-16D	Max. 2.5% Per 1000 Hr (B.L * x 0.70)	
		5/16	7.9	+0.016 -0.008	+0.4 -0.2	196	293	14,550	6,600	12,340	5,600	3.5	12-16D		
		3/8	9.3	+0.016 -0.008	+0.4 -0.2	272	405	19,950	9,050	16,970	7,700	3.5	12-16D		
		7/16	10.8	+0.016 -0.008	+0.4 -0.2	366	546	26,890	12,200	22,390	10,400	3.5	12-16D		
		1/2	12.4	+0.016 -0.008	+0.4 -0.2	489	729	35,390	16,300	30,640	13,900	3.5	12-16D		
		0.6	15.2	+0.016 -0.008	+0.4 -0.2	739	1101	54,010	24,500	45,850	20,800	3.5	12-16D		
	SWPC 7B (190kg/mm ²)	3/8	9.5	9.5	+0.016 -0.008	+0.4 -0.2	290	432	22,930	10,400	19,510	8,850	3.5		12-16D
		7/16	11.1	11.1	+0.016 -0.008	+0.4 -0.2	389	580	31,080	14,100	26,450	12,000	3.5		12-16D
		1/2	12.7	12.7	+0.016 -0.008	+0.4 -0.2	520	774	41,220	18,700	35,050	15,900	3.5		12-16D
		0.6	15.2	15.2	+0.016 -0.008	+0.4 -0.2	739	1101	58,640	26,600	49,820	22,600	3.5		12-16D

B.L*:Breaking Load



X-BON SUPER-BON



X-BON SUPER-BON

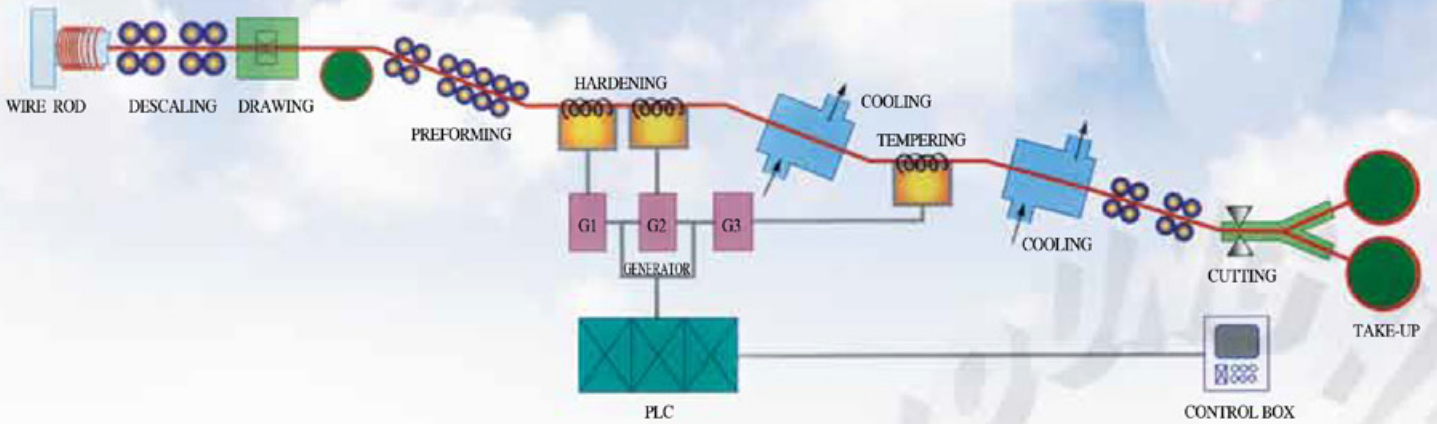

X-BON SUPER-BON



USE & TYPE OF PRODUCT



X Bon

Super-Bon

This has the same standard and mechanical properties as that of X-BON deformed P.C. D-grade is suitable when preventing corrosion by salt and P.C concrete products needing high-heated relaxation.

Type of Product	Grade	Dia.	Uses	Remark
X-BON Deformed PC	C	5 x 13mm	<ul style="list-style-type: none"> • Concrete pole & pile reinforcement • Post of building & reinforcement for beam • Reinforcement for fume pile 	Pole Building
	D		<ul style="list-style-type: none"> • Pile • Pole • Fume Pile • Beam 	Bridge House
SUPER-BON Deformed PC	D		<ul style="list-style-type: none"> • Sheet Pile • High Stressed Pile 	Harbor Wharf

Super Bon



The Characteristics of Product

Our company's X-BON & SUPER-BON deformed PC Steel Bar are products with excellent mechanical and processing properties as below and produced according to KS D 3505 & JIS G 3137.



Classification	Characteristic
Mechanical Property	<ol style="list-style-type: none"> 1. Able to make the Reinforced Concrete lighter which permits better economy of design. 2. Very easy to spot weld, but little changed to the mechanical property even if processed by heading screw method. 3. Very economical, due to the high elastic limit point and the extremely low relaxation. 4. This mechanical property contributes to the quality improvement with yield ratio of 90% which is 10% higher than minimum value of fatigue. This is essential to the PC steel bar.
Adhesion	<ol style="list-style-type: none"> 1. Tensile strength is improved because surface if processed with the form of spiral defeat and the adhesion is bigger than pc wires. 2. Due to the excellent adhesion, the production cost is reduced, and productivity improves. 3. Due to the good rate of stress, removing the crack occurred in the reinforced concrete.
Utility	<ol style="list-style-type: none"> 1. It does not need a process in straight line because it is coiled within the elastic limit, with maintaining a perfect straight line while releasing. 2. You can process with screw without the necessity of peeling procedure because the dia of product was produced for the screw process.

Quality Properties of Product

1. CHEMICAL COMPOSITION

P	S	Cu
Max. 0.03	Max. 0.035	Max. 0.30

KS D 3505 and JIS G 3137 state the following diagram of "P,S,Cu". As the impurities of raw-material(wire rod).

YOUNG HEUNG meets this base line and uses the best materials to adhere to all mechanical properties of P.C Steel Bar including tensile load, yield load, relaxation, spot welding.

2.SHAPE, DIA & TOLERANCE

Type of Wire	Grade	Nominal Dia. (mm)	Basic Dia. (mm)	Tolerance (mm)	Nominal cross section area (mm ²)	Mass (kg/m)	No of groove/Lay	Groove Shape
X-BON C (KS D 3505) (C Grade,No.1)	SBPD (110/125) SBPD (1080/1230)	5.0	5.0	±0.05	18.07	0.142	2/Z	
		7.0	7.0		35.40	0.278	2/Z	
		8.0	8.0		46.25	0.363	2/Z	
		11.0	11.0		87.30	0.685	4/Z	
		13.0	13.0		122.11	0.958	4/Z	
X-BON D SUPER-BON D (KS D 3505) (D Grade,No.1)	SBPD (130/45) SBPD (1275/1420)	6.1	6.10	±0.05	28.27	0.222	3/S	
		7.4	7.25		40.0	0.315	3/S	
		8.3	8.33		52.5	0.412	4/S	
		9.2	9.25		64.0	0.500	6/S	
		11.0	11.10		90.0	0.710	6/S	
		13.0	13.10		125.0	0.980	6/S	



*Tolerance is for basic diameter.

*It's available to supply the product of size 5~13mm by K.S specification per customer's order.

X-BON SUPER-BON



3. MECHANICAL PROPERTIES

The mechanical property of X-BON & SUPER-BON complies with the spec. of KS D 3505 or JIS G 3137

Type of Wire	Nominal Dia.	Yield Point (min.)	Yield Strength (min.)	Min. Breaking Load	Tensile Strength (min.)	Elongation (min.)	Relaxation (min.)
	mm	kg	kg/mm ²	kg	kg/mm ²	%	%
X-BON C (110/125)	5.0	2,080	115	2,530	140	5.0	1.5
	7.0	4,070		4,780	135		
	8.0	5,320		6,240			
	11.0	10,040		11,350			
	13.0	14,040		15,260			
X-BON D (130/145)	6.1	3,820	130	4,100	145	5.0	1.5
	7.4	5,400		5,800			
	8.3	7,090		7,610			
	9.2	8,460		9,280			
	11.0	11,900		13,050			
	13.0	16,500		18,130			
SUPER-BON D (130/145)	6.1	3,900	130	4,100	145	5.0	1.0
	7.4	5,520		5,800			
	8.3	7,250		7,610			
	9.2	8,660		9,280			
	11.0	12,200		13,050			
	13.0	16,900		18,130			

※ Regarding mechanical property, able to be supplied with the production by order customer requires.

※ REMARKS

- 1) Yield point means the load against permanent elongation of 0.2%.
- 2) Elongation means elongation after fracture at the original gauge length which is 8 times of nominal dia.
- 3) Relaxation is the value acquired by testing 80% of yield strength with the initial load for 10 hours on the normal temperature.



COLD DRAWN STEEL BARS



COLD DRAWN STEEL BARS

GENERAL INFORMATION



Young Heun's CD-BAR creates the perfect quality required by customers with our very modern facility using the "SCHUMAG Combined Bar Machine".

Material is of highest quality and is produced with the latest technology available.

- Highest Quality
- Most Dependable Delivery
- Best Price
- Various Products



PRODUCTION RANGE

FORMS OF SUPPLY	SIZE RANGE	LENGTH	MATERIAL
Rounds	5mm ~ 30mm	2m ~ 6m	Free Cutting Steel
Hexagons	5mm ~ 25mm	2m ~ 6m	Carbon Steel
Squares	5mm ~ 20mm	2m ~ 6m	Alloy Steel
Irregular Shape	-	-	Suspension Spring etc.

TOLERANCE GRADE

<Unit : mm>

Dia. \ Grade	H7	H8	H9	H10	H11	H12
5.0 - 6.0	0 ~ -0.012	0 ~ -0.018	0 ~ -0.030	0 ~ -0.048	0 ~ -0.075	0 ~ -0.12
6.10 - 10.0	0 ~ -0.015	0 ~ -0.022	0 ~ -0.036	0 ~ -0.058	0 ~ -0.090	0 ~ -0.15
10.01 - 18.0	0 ~ -0.018	0 ~ -0.027	0 ~ -0.043	0 ~ -0.070	0 ~ -0.11	0 ~ -0.18
18.01 - 30.0	0 ~ -0.021	0 ~ -0.033	0 ~ -0.052	0 ~ -0.084	0 ~ -0.13	0 ~ -0.21
BAR LENGTH	2~6m	2 ~ 6m	2~6m	2~6m	2~6m	2~6m
BAR SHAPE	○	○	○	○ □	○ □	○ □



FREE CUTTING STEEL

Young Heung's Free-Cutting Steel has equal quality throughout.
 It has excellent mechanical properties.
 Improve the efficiency of manufacture with the excellent machine of our free cutting steels.
 /Extend the life of machine tools/Available for the automotive, robotic industries.

Application :

- OA Instruments
- Optical Instruments
- Automotives



FREE CUTTING STEEL

SPECIFICATION			Chemical Composition(%)					
KS	JIS	SAE	C	Si	Mn	P	S	pb
SUM21	SUM21	1212	max 0.13	0.15~0.35	0.70~1.00	0.70~0.12	0.16~0.23	
SUM22	SUM22	1213	max 0.13	0.15~0.35	0.70~1.00	0.70~0.12	0.24~0.33	
SUM22L	SUM22L	12L12	max 0.13	0.15~0.35	0.70~1.00	0.70~0.12	0.24~0.33	0.10~0.35
SUM23	SUM23	1215	max 0.09	0.15~0.35	0.75~1.05	0.04~0.09	0.26~0.35	
SUM24L	SUM24L	12L14	max 0.15	0.15~0.35	0.85~1.15	0.04~0.09	0.26~0.35	0.10~0.35
SUM31	SUM31	1117	0.14~0.20	0.15~0.35	1.00~1.30	max 0.040	0.08' 0.13	
SUM41	SUM41	1137	0.32~0.39	0.15~0.35	1.35~0.65	max 0.040	0.08~0.13	
SUM43	SUM43	1144	0.40~0.48	0.15~0.35	1.35~1.65	max 0.040	0.24~0.33	

MACHINE STRUCTURAL CARBON STEEL



We take great pride in
Our highest quality of Machine Structural Carbon
Steels

- Good surface condition
- Uniformity and accuracy
of outside diameter
- Various length of bar

Application :

- Automotives

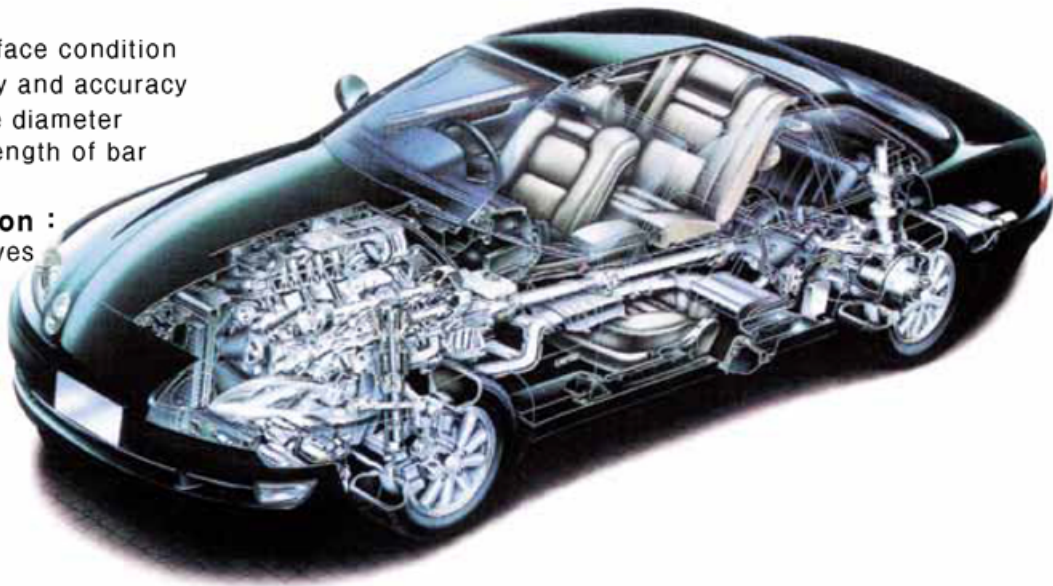

MACHINE STRUCTURAL CARBON STEEL

SPECIFICATION			Chemical Composition(%)				
KS	JIS	SAE	C	Si	Mn	P	S
SM10C	S10C	1010	0.08~0.13	0.15~0.35	0.30~0.60	max 0.030	max 0.035
SM15C	S15C	1015	0.13~0.18	0.15~0.35	0.30~0.60	max 0.030	max 0.035
SM20C	S20C	1020	0.18~0.23	0.15~0.35	0.30~0.60	max 0.030	max 0.035
SM25C	S25C	1025	0.22~0.28	0.15~0.35	0.30~0.60	max 0.030	max 0.035
SM30C	S30C	1030	0.27~0.33	0.15~0.35	0.60~0.90	max 0.030	max 0.035
SM38C	S35C	1038	0.35~0.41	0.15~0.35	0.60~0.90	max 0.030	max 0.035
SM40C	S40C	1040	0.37~0.43	0.15~0.35	0.60~0.90	max 0.030	max 0.035
SM45C	S45C	1045	0.42~0.48	0.15~0.35	0.60~0.90	max 0.030	max 0.035
SM50C	S50C	1050	0.47~0.53	0.15~0.35	0.60~0.90	max 0.030	max 0.035
SM55C	S55C	1055	0.55~0.61	0.15~0.35	0.60~0.90	max 0.030	max 0.035



SPRING STEELS & MACHINE STRUCTURAL ALLOY STEELS



We will do our best in order to develop special steel to meet customer requirements at all times.

- Suspension-Spring
- Torsion-Bar
- Stabilized-Bar
- Alloy Steel (Available by special order)
- Application: Bolt, Wrench, Tools, Spring applications.



SPRING STEEL

STEEL GRADE	Chemical Composition(%)						
	C	Mn	Si	P	S	Cr	V
SAE 9260(SUP7)	0.56~0.64	0.70~1.00	1.80~2.20	max0.035	max0.035	-	-
SAE 9254(SUP12)	0.51~0.59	0.60~0.80	1.20~1.60	max0.035	max0.035	0.60~0.80	-
SRS 60(KOBE)	0.58~0.63	0.35~0.60	1.35~1.60	max0.035	max0.035	0.40~0.70	0.15~0.25
SAE 5155(SUP9)	0.52~0.60	0.65~0.95	0.15~0.35	max0.035	max0.035	0.65~0.95	-
SAE 5160(SUP9A)	0.56~0.64	0.70~1.00	0.15~0.35	max0.035	max0.035	0.70~1.00	-

*Material : KOBE



MACHINE STRUCTURAL ALLOY STEEL

SPECIFICATION				Chemical Composition(%)						
KS	JIS	AIS/SAE	DIN	C	Si	Mn	P	S	Cr	Mo
SCM1	SCM432	-	-	0.27~0.37	0.15~0.35	0.30~0.60	max0.030	max0.030	1.00~1.50	0.15~0.30
SCM2	SCM430	4130	-	0.28~0.33	0.15~0.35	0.60~0.85	max0.030	max0.030	0.90~1.20	0.15~0.30
SCM3	SCM435	4135/4137	34CrMo4	0.33~0.38	0.15~0.35	0.60~0.85	max0.030	max0.030	0.90~1.20	0.15~0.30
SCM4	SCM440	4140/4142	42CrMo4	0.38~0.43	0.15~0.35	0.60~0.85	max0.030	max0.030	0.90~1.20	0.15~0.30
SCM5	SCM445	4145/4147	-	0.43~0.48	0.15~0.35	0.60~0.85	max0.030	max0.030	0.90~1.20	0.15~0.30
SCM21	SCM415	-	16CrMo4	0.13~0.18	0.15~0.35	0.60~0.85	max0.030	max0.030	0.90~1.20	0.15~0.30
SCM22	SCM420	4148	50CrMo4	0.18~0.23	0.15~0.35	0.60~0.85	max0.030	max0.030	0.90~1.20	0.15~0.30
SCM23	SCM421	-	-	0.17~0.23	0.15~0.35	0.70~1.00	max0.030	max0.030	0.90~1.20	0.15~0.30
SCM24	SCM822	-	22CrMo44	0.20~0.25	0.15~0.35	0.60~0.85	max0.030	max0.030	0.90~1.20	0.35~0.45



REFERENCE CHARTS

Wire Gauge Table

GAUGE NUMBER	S.W.G. mm	B.W.G mm	B. & S. mm	A.S.W.G mm	J.deP. mm	W.G. mm	B.G. mm	U.S.S mm
#000000	12.699			12.45				12.700
#000000	11.785		14.73	11.72				11.906
#00000	10.972		13.12	10.93				11.113
#0000	10.159	11.532	11.68	10.00				10.319
#000	9.448	10.795	10.40	9.208	(pp).400		12.700	9.525
#00	8.839	9.652	9.266	8.407	(p).500		11.308	8.731
#0	8.229	8.636	8.255	7.785	.600	.60	10.069	7.938
#1	7.620	7.620	7.348	7.188	.700	.68	8.971	7.144
#2	7.010	7.213	6.543	6.698	.800	.76	7.993	6.747
#3	6.401	6.579	5.827	6.190	.900	.80	7.122	6.350
#4	5.893	6.045	5.189	5.723	1.000	.88	6.350	5.953
#5	5.385	5.558	4.620	5.258	1.100	1.00	5.652	5.556
#6	4.877	5.156	4.115	4.877	1.200	1.12	5.032	5.159
#7	4.470	4.572	3.665	4.496	1.300	1.20	4.481	4.763
#8	4.064	4.191	3.264	4.115	1.400	1.30	3.988	4.366
#9	3.658	3.759	2.906	3.767	1.500	1.40	3.551	3.969
#10	3.251	3.404	2.588	3.429	1.600	1.56	3.175	3.572
#11	2.946	3.048	2.304	3.061	1.800	1.66	2.827	3.175
#12	2.642	2.769	2.052	2.680	2.000	1.84	2.517	2.778
#13	2.337	2.413	1.826	2.324	2.200	2.04	2.240	2.381
#14	2.032	2.108	1.628	2.032	2.400	2.20	1.994	1.984
#15	1.829	1.829	1.450	1.829	2.700	2.40	1.775	1.786
#16	1.626	1.651	1.290	1.588	3.000	2.60	1.588	1.588
#17	1.422	1.473	1.151	1.372	3.400	2.92	1.412	1.429
#18	1.219	1.245	1.024	1.207	3.900	3.40	1.257	1.270
#19	1.061	1.067	.9116	1.041	4.400	3.84	1.118	1.111
#20	.9144	.8886	.8128	.8839	4.900	4.20	.9956	.9525
#21	.8128	.8128	.7239	.8052	5.400	4.65	.8865	.8731
#22	.7112	.7109	.6426	.7264	5.900	5.45	.7938	.7938
#23	.6096	.6347	.5740	.6553	6.400	5.96	.7066	.7144
#24	.5588	.5585	.5105	.5842	7.400	7.00	.6289	.6350
#25	.5080	.5078	.4547	.5182	7.600	7.60	.5589	.5556
#26	.4572	.4570	.4039	.4597	8.200	8.80	.4981	.4763
#27	.4166	.4062	.3607	.4394	8.800	9.40	.4432	.4366
#28	.3759	.3555	.3200	.4115	9.400	10.00	.3369	.3969
#29	.3454	.3300	.2875	.3810	10.000		.3531	.3572
#30	.3150	.3046	.2540	.3556			.3124	.3175
#31	.2946	.2539	.2268	.3353			.2794	.2778
#32	.2743	.2286	.2019	.3251			.2489	.2580
#33	.2540	.2031	.1798	.2997			.2210	.2381
#34	.2337	.1777	.1600	.2642			.1956	.2183
#35	.2134	.1269	.1425	.2413			.1753	.1984
#36	.1930	.1016	.1270	.2286			.1549	.1786
#37	.1727		.1120	.2159			.1372	.1687
#38	.1524		.1006	.2032			.1219	.1588
#39	.1321		.0897	.1905				
#40	.1219		.0798	.1778				

S.W.G.....British Imperial Standard Wire Gauge

B.W.G.....Birmingham Wire Gauge.

B. & s.....Brown and Sharp Wire Gauge

A.S.W.G..American steel & Wire Gauge

J.deP...Paris Wire Gauge.

W.G....Westphalia Wire Gauge.

B.G....Standard Birmingham Sheet and Hoop

U.S.S...U.S.Standard for Sheet and Plate Iron and Steel



REFERENCE CHARTS

SI Units and MKS Weight(Former) Unit Conversion Table(units used daily)

Volume	SI unit	former unit
Strength(breaking load)	1N	0.101972 kgf
	9.80665 N	1kgf
Tension(pull strength)and flexibility coefficient	1N/mm ² [=1Mpa = 0.1hbar]	0.101972 kgf/mm ²
	9.80665N/mm ²	1kgf/mm ²
Torque	1N · m	0.101972kgf·m
	9.80665 N · m	1kgf · m
Production volume and amount used	1kg(1t)	1kg(1t)
Unit mass	1kg/m(mass)	1kg/m(weight)
Coating adherence volume	1g/m ²	1g/m ²
Heat value, job, energy	1J	0.238889cal[=0.101972×10 ⁻¹ kgf · m]
	4.18605J	1cal
	9.80665J	1kgf · m
Plane angle	1 rad	57° 17' 44" 8
	0.01744 rad	1°

Conversion Table

1) Conversion of the thickness

Circumference ×0.3183=Diameter
 Diameter(in)×25.4=Diameter(mm)
 Diameter×3.1416=Circumference
 Diameter×0.1237=Circumference(in)
 Circumference(in)×8.0851=Diameter(mm)
 Diameter(mm)×0.03937=Diameter(in)

2) Conversion of unit mass

kg/m×0.67196=1b/ft
 1b/ft×1.4882=kg/m
 Unit mass of 100-meter steel wire=[wire diameter (mm)]² × 0.6126(kg)
 [the weight shall be set as 7.8]

3) Conversion of the pull strength

kgf/mm² × 0.635=t/in²
 kgf/mm² × 1422.3=1b/in²
 t/in² × 1.5748=kgf/mm²
 1b/in² × 0.0007031=kgf/mm² (100.0001b/in² =70.31kgf/mm²)

4) Conversion of coating adhesion volume

g/m² × 0.0033=oz(ounce)ft²
 oz/ft² × 305.152=g/m²

Weights and Measures Comparison Table

1) Comparison table of length

Yard · Pound method				Meter method	
Mile	Yard	Feet	Inch	Meter	Millimeter
2.4403	4,294.9	12,885		3,927.3	
	119.3	357.92		3,927.3	
	1.988	5.965		1.818	1,818
1	1,760	5,280	11.931	0.303	303
	1	3	36	0.9144	914.38
		1	12	0.30479	304.79
1.0936		0.0833	1	0.0254	25.4
		3.281	39.371	1	1,000
			0.0394	0.001	1

One nautical mile =1,852meters
 One fathom=6.0feet=1.829meters
 One mil=0.001inch=0.0254millimeters

2) Unit mass comparison table

Yard · Pound method			Meter method		
Ton (English)	Pound	Ounce	Ton	Kilogram	Cram
0.00369	1.32277	21.1641		0.6	600
	8.2673	132.277	0.00375	3.75	3.750
		0.13227			3.75
1	2,240	35.840	1.01605	1,016.05	
	1	16		0.4536	453.59
		1			28.349
0.98420	2,204.62		1	1,000	
	2.2046		0.001	1	1,000
		0.03527		0.001	1

One ton(U.S.)(short ton)=2,000pounds=907.185kilograms



YOUNG HEUNG IRON & STEEL CO., LTD.

Seoul office

10Th Floor. Keungil Tower B/D 677-25
Yeoksam-Dong Gangnam-gu Seoul.Korea
TEL. 82-2-2077-8551~8555
FAX. 82-2-2077-8513/8515
E-mail. export@youngwire.com
URL : <http://www.youngwire.com>

ChangWon Factory

71-1, SinChon-Dong ChangWon City, GyungNam, Korea
TEL. 82-55-282-2241
FAX. 82-55-282-2676

HamAn Factory

185, PyungLim-Ri, DaeSan-Myun, HamAn-Gun, GyungNam, Korea
TEL. 82-55-582-2851
FAX. 82-55-582-2900

China Factory

Port Development Zone LiuJia Gang,
TaiCang City, JiangSu, China
TEL. 86-512-53646561~3
FAX. 86-512-53646564